



US 20130235610A1

(19) **United States**

(12) **Patent Application Publication**  
**Yang et al.**

(10) **Pub. No.: US 2013/0235610 A1**

(43) **Pub. Date: Sep. 12, 2013**

(54) **VANITY MIRROR**

**Publication Classification**

(71) Applicant: **SIMPLEHUMAN, LLC**, Torrance, CA (US)

(51) **Int. Cl.**  
**F21V 33/00** (2006.01)  
**F21V 8/00** (2006.01)  
**F21V 11/00** (2006.01)

(72) Inventors: **Frank Yang**, Rancho Palos Verdes, CA (US); **David Wolbert**, Redondo Beach, CA (US); **Joseph Sandor**, Newport Beach, CA (US); **Orlando Cardenas**, Laguna Niguel, CA (US); **Frederick N. Bushroe**, Tucson, AZ (US)

(52) **U.S. Cl.**  
CPC ..... **F21V 33/0004** (2013.01); **F21V 11/00** (2013.01); **G02B 6/0096** (2013.01)  
USPC ..... **362/555**; 362/135; 362/551; 29/428

(73) Assignee: **SIMPLEHUMAN, LLC**, Torrance, CA (US)

(57) **ABSTRACT**

(21) Appl. No.: **13/783,109**

A mirror assembly can include a housing, a mirror, and a light source. In certain embodiments, the mirror includes a light pipe configured to emit a substantially constant amount of light along a periphery of the mirror. In some embodiments, the mirror assembly includes a sensor assembly. The sensor assembly can be configured to adjust the amount of emitted light based on the position of a user in relation to the mirror. Certain embodiments of the mirror include an algorithm to adjust light based on the position of a user relative to the mirror, the level of ambient light, and/or the activation of different light modes.

(22) Filed: **Mar. 1, 2013**

**Related U.S. Application Data**

(60) Provisional application No. 61/608,584, filed on Mar. 8, 2012.

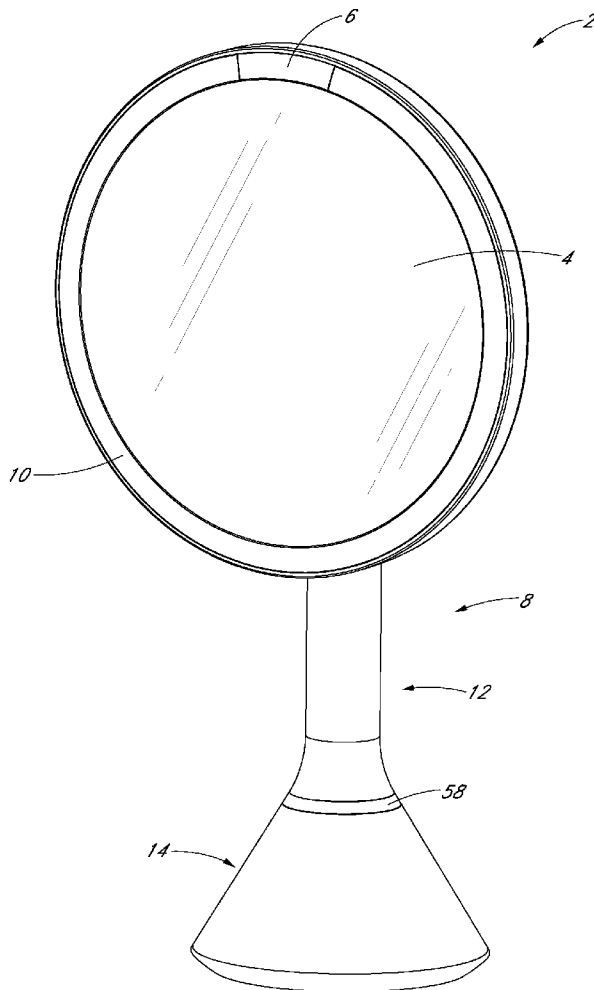

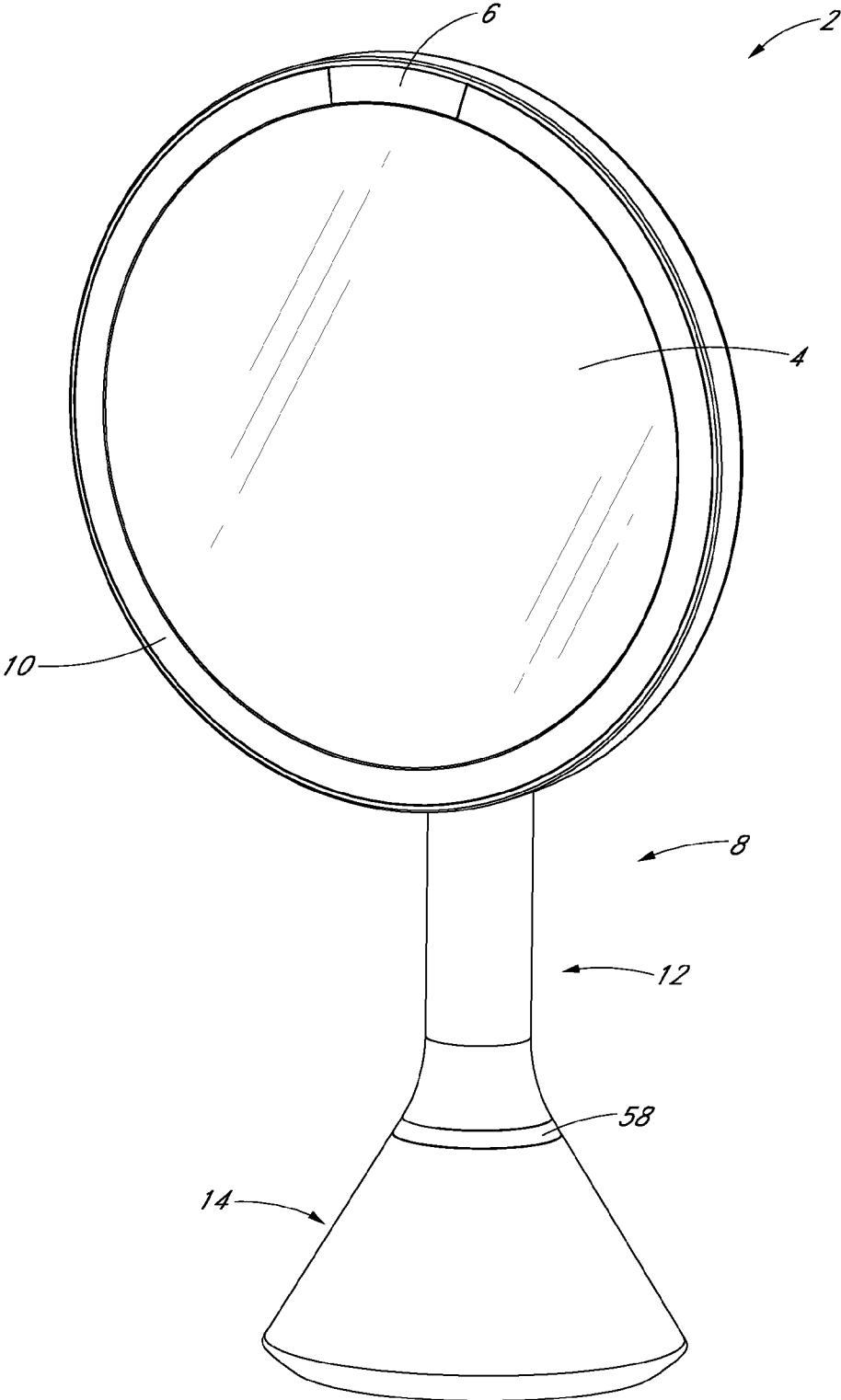
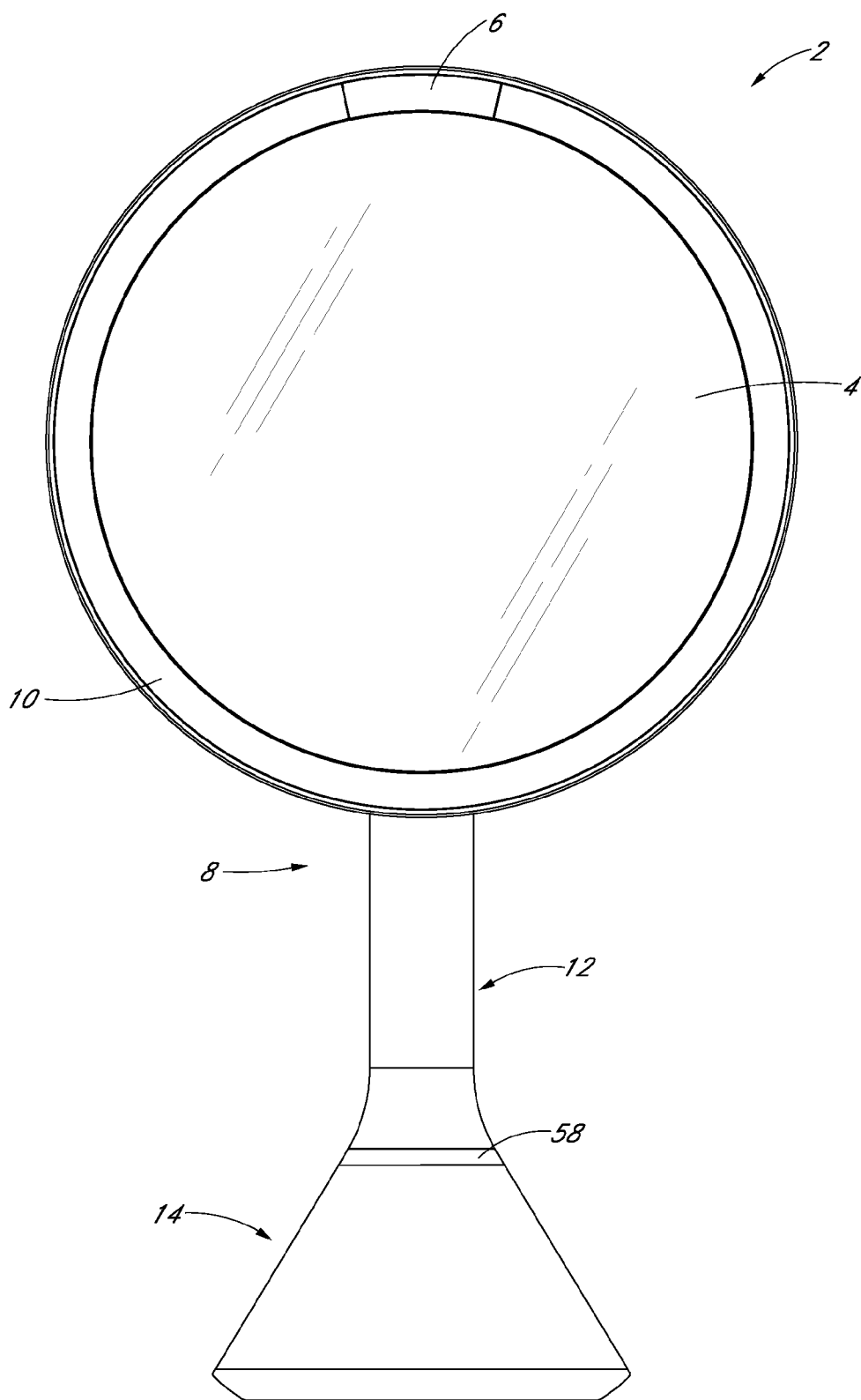
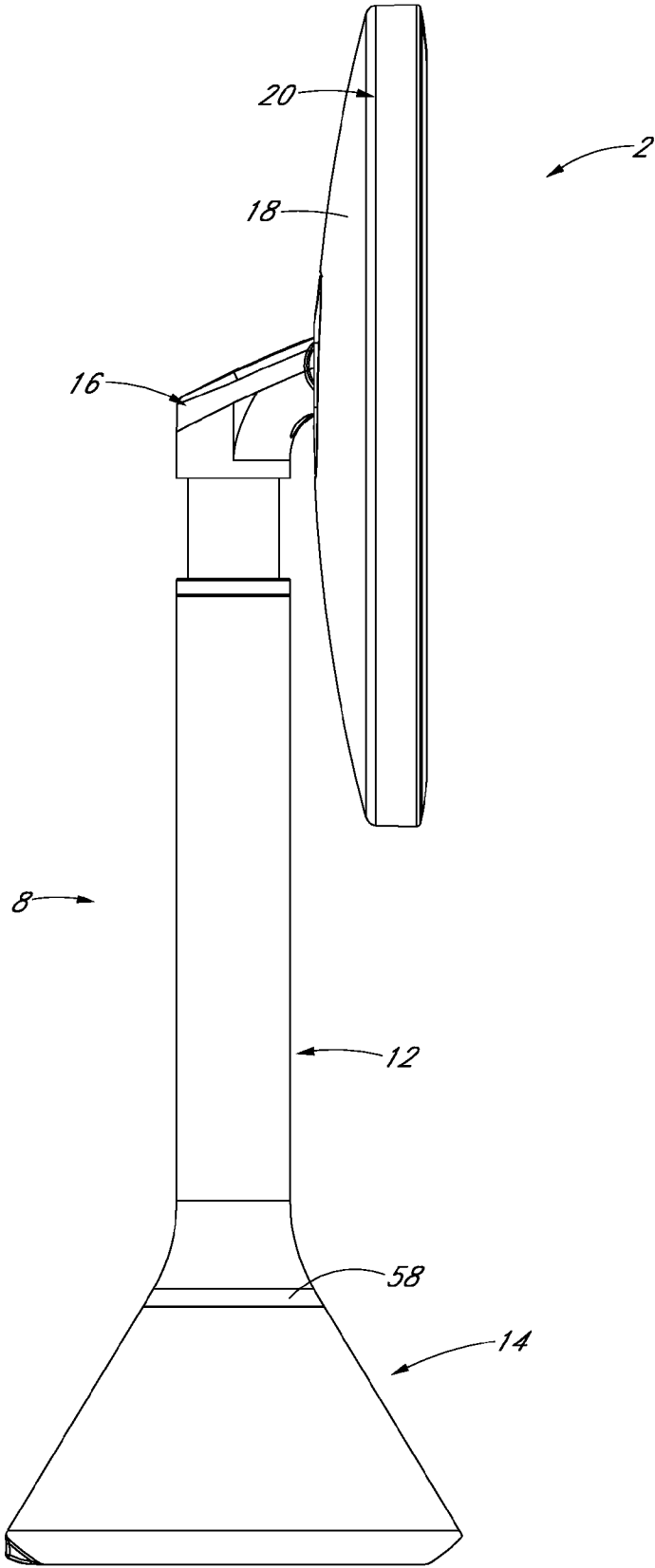

FIG. 1



*FIG. 2*



*FIG. 3*

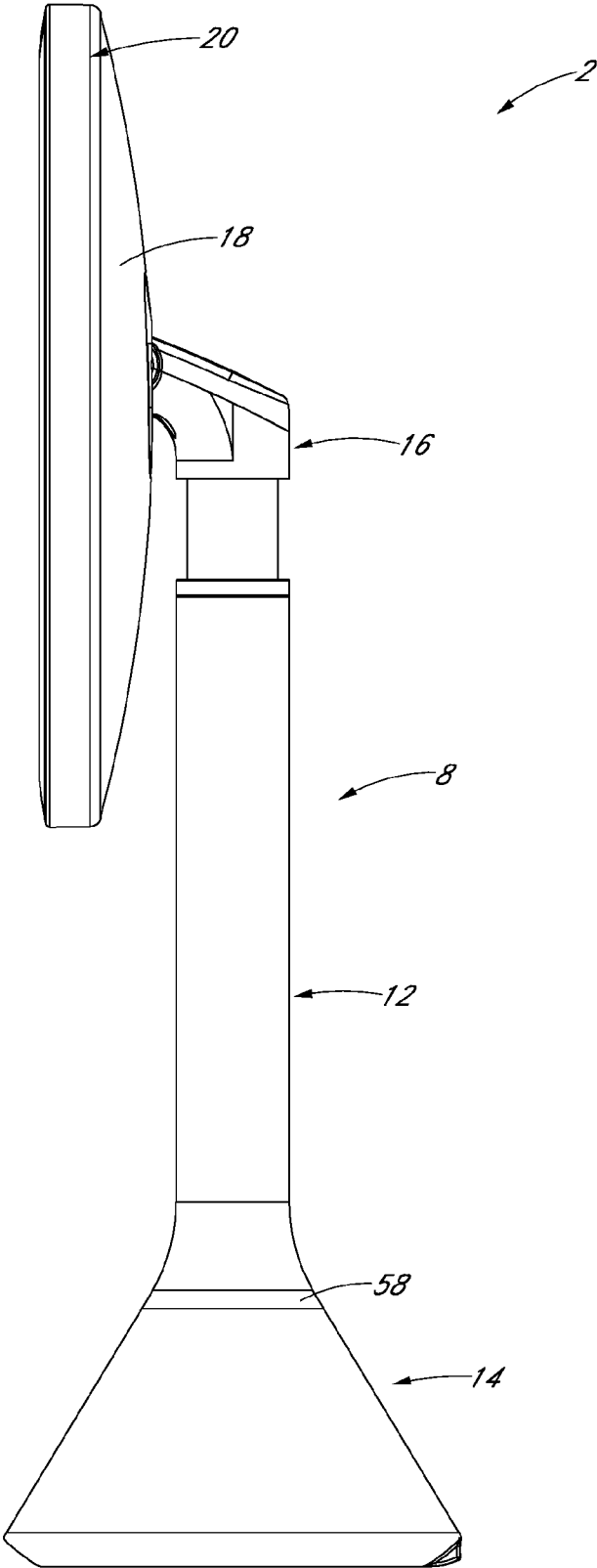
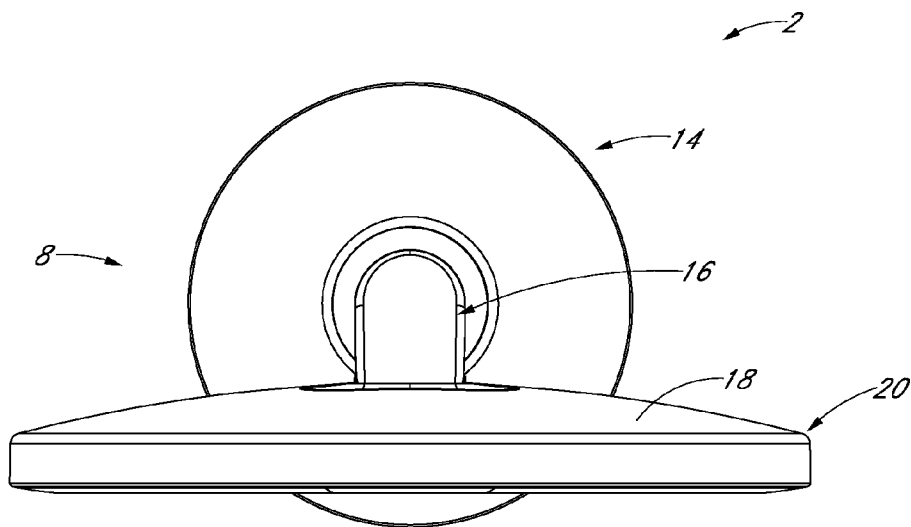
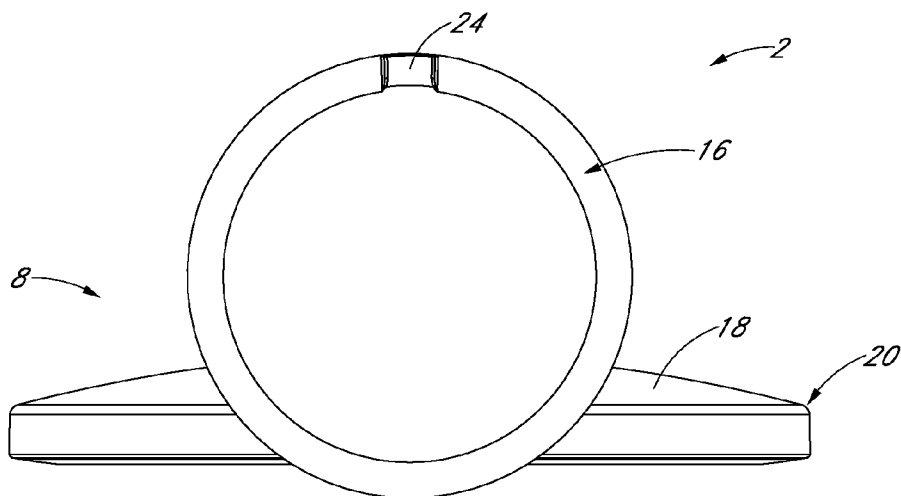

FIG. 4



*FIG. 5*



*FIG. 6*

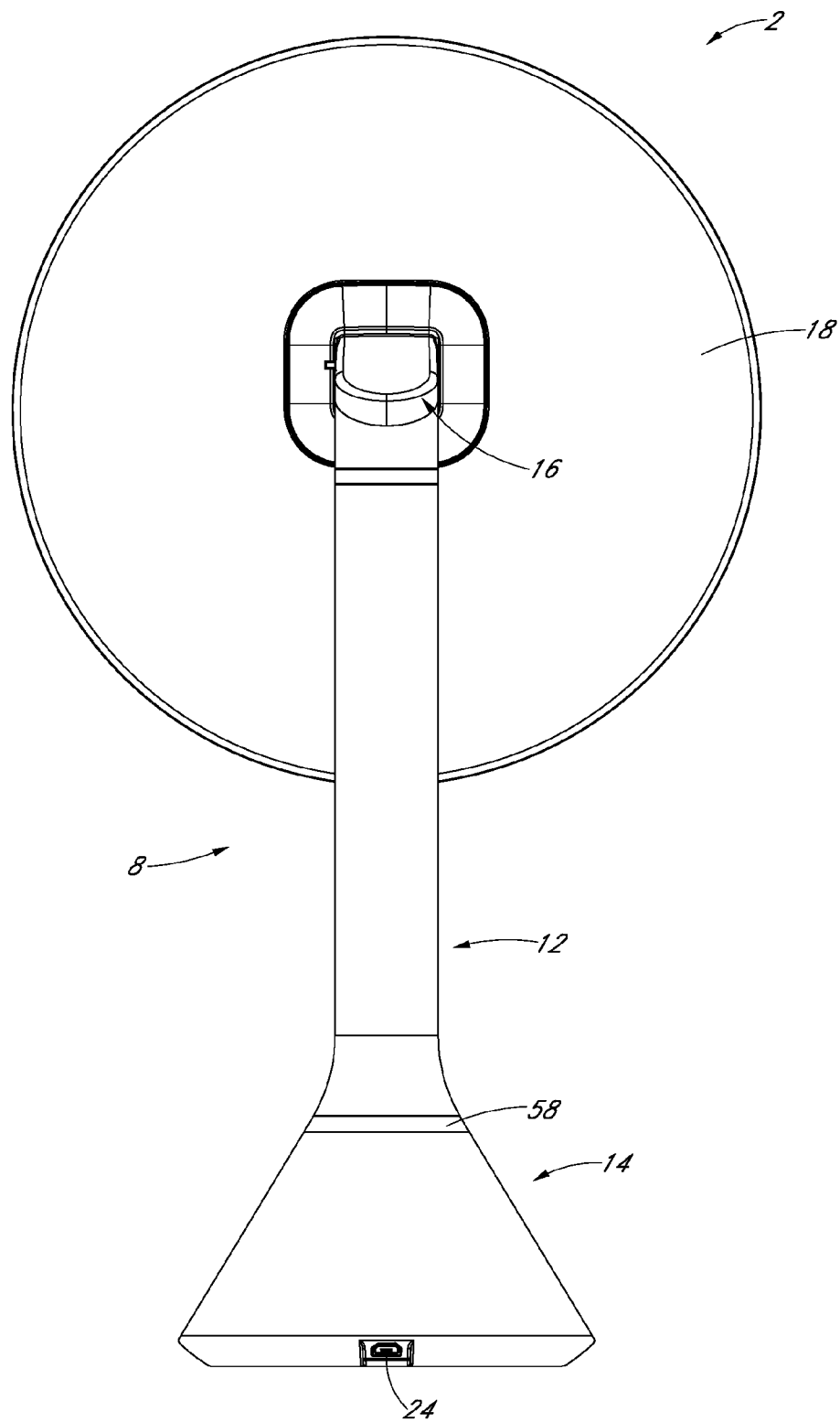

FIG. 7

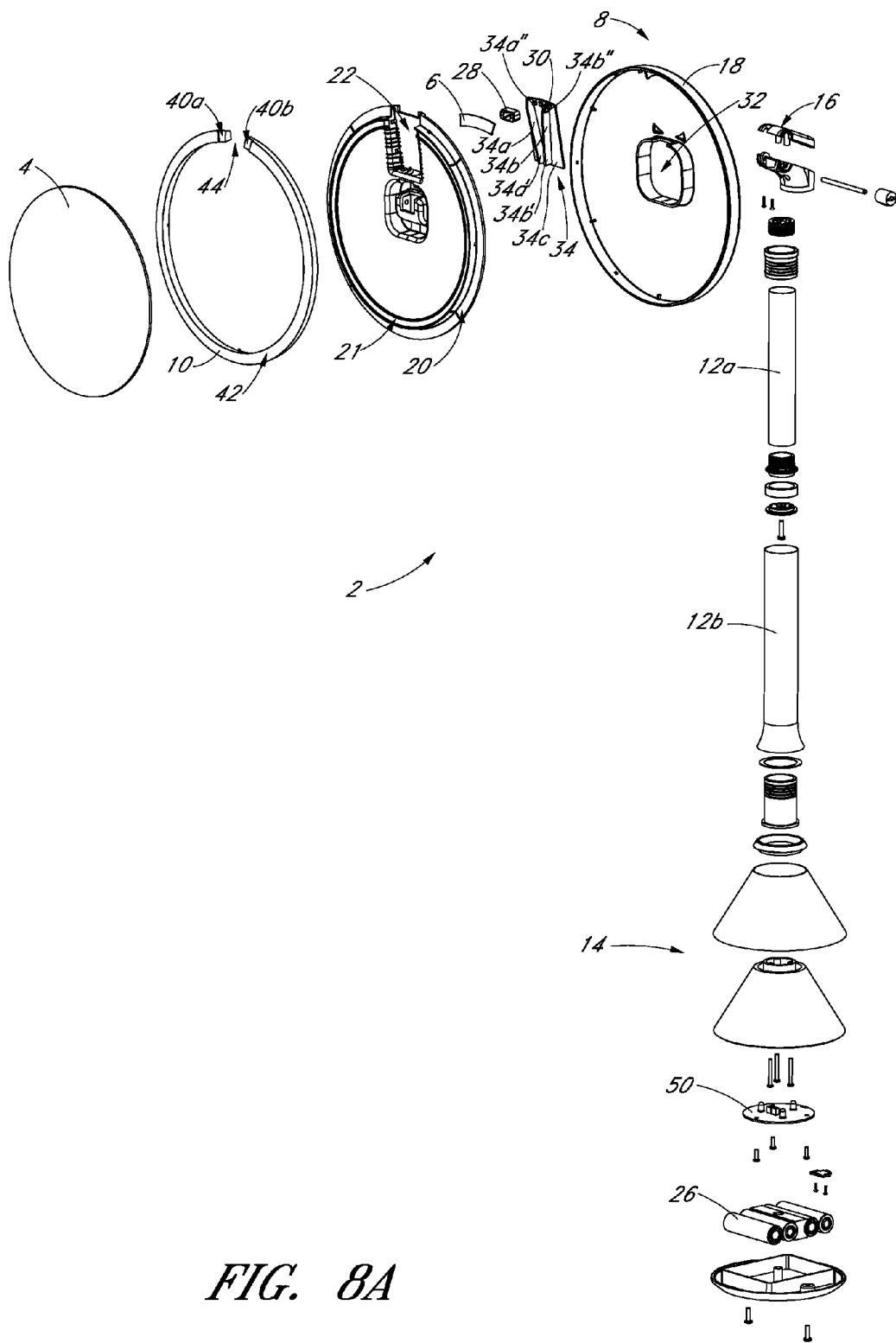

FIG. 8A



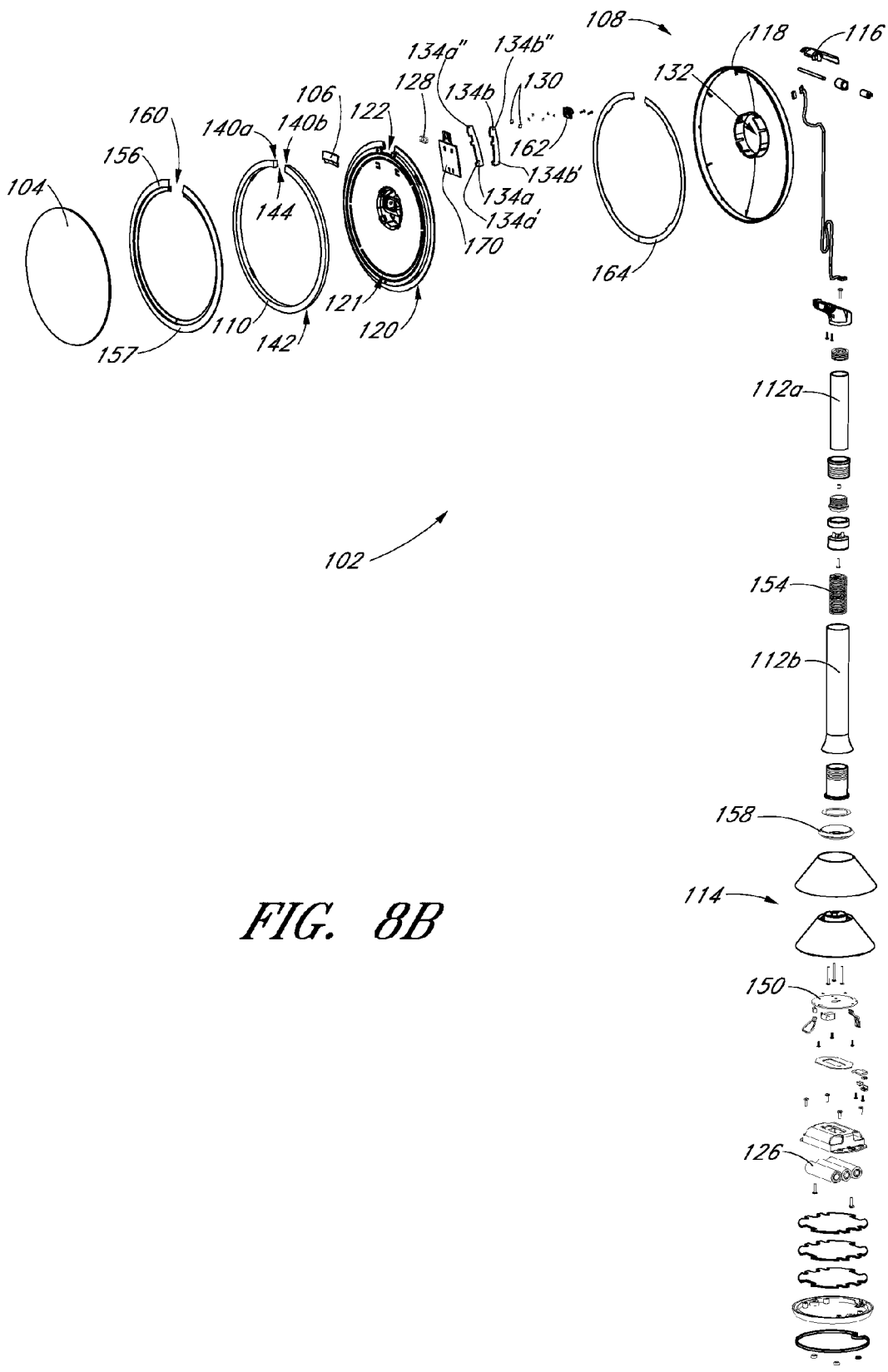

FIG. 8B

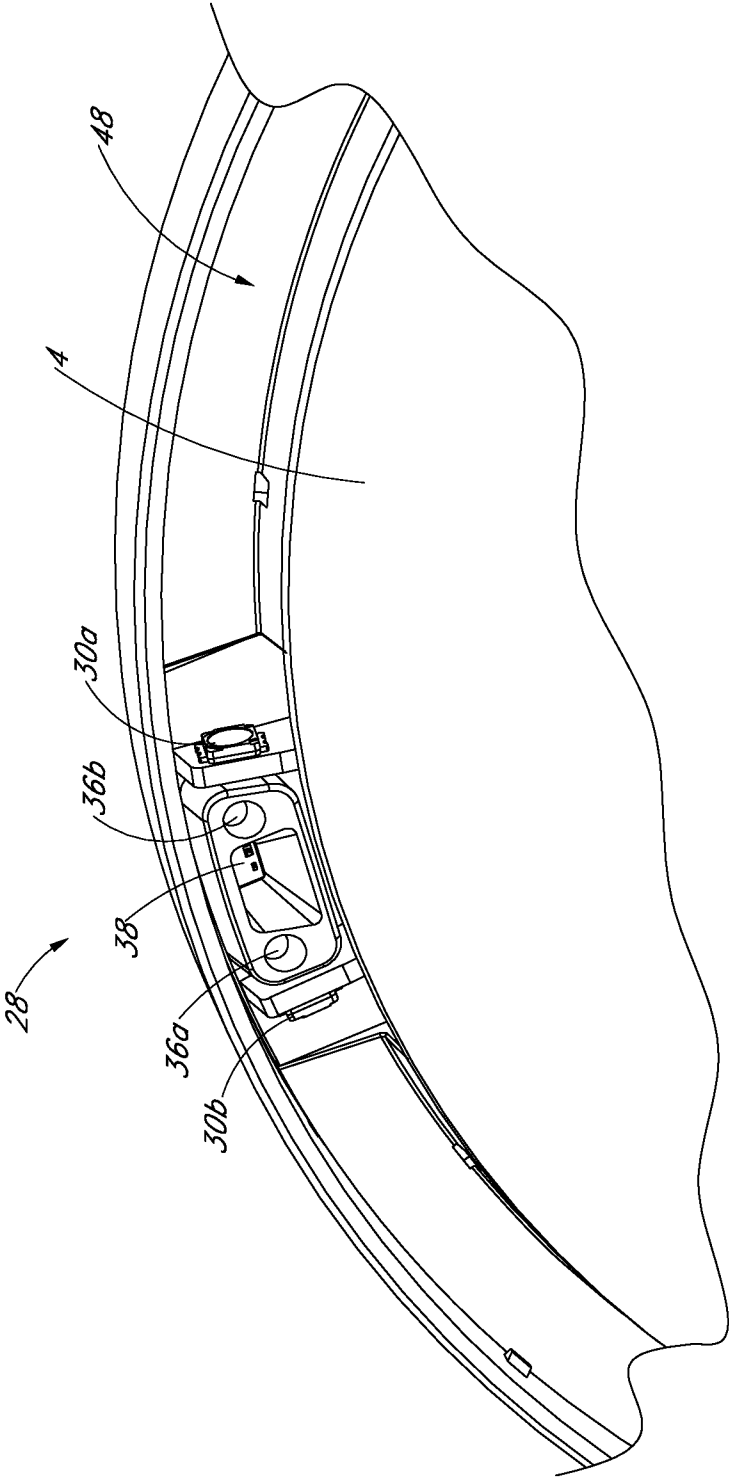

FIG. 9

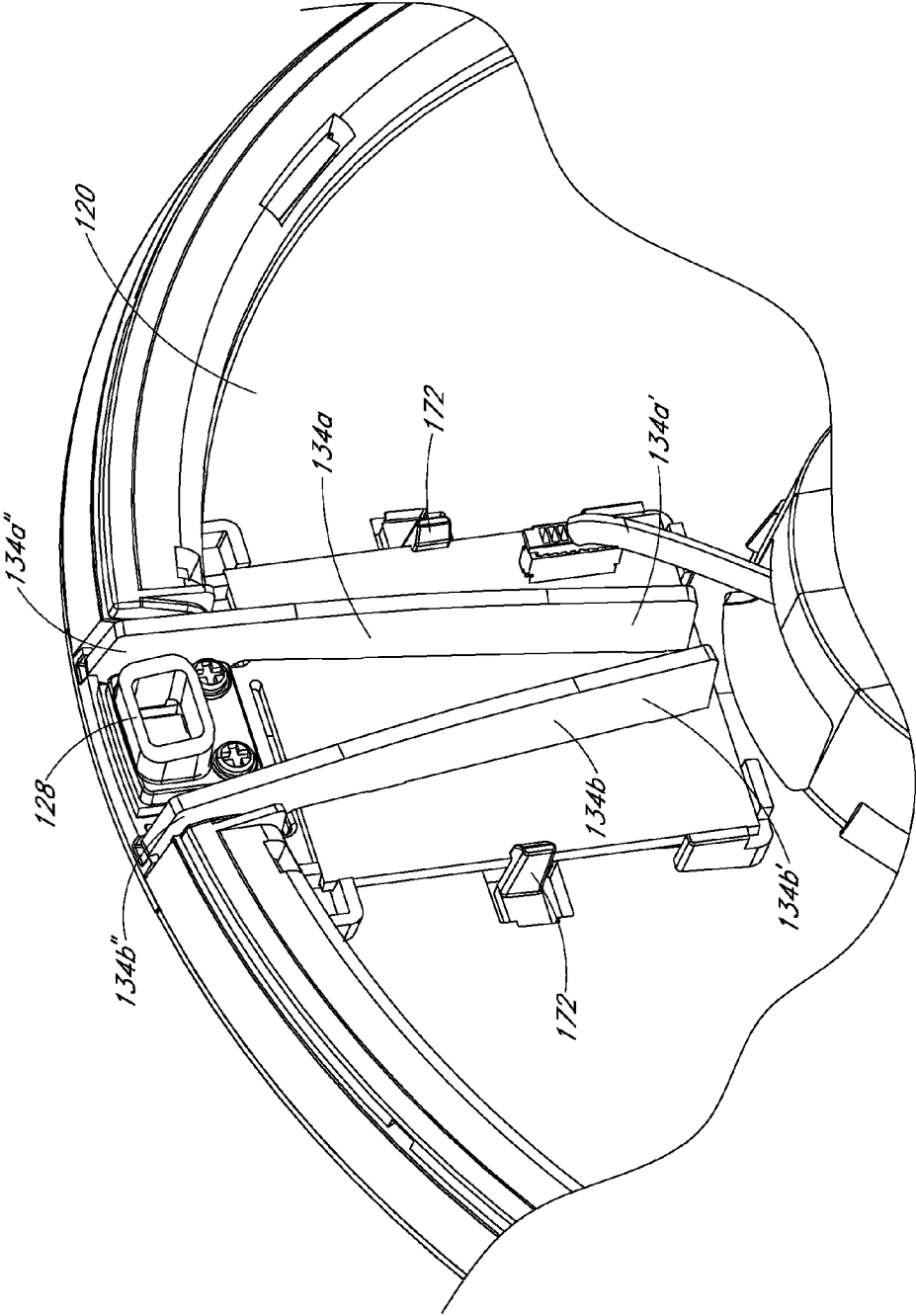

FIG. 10

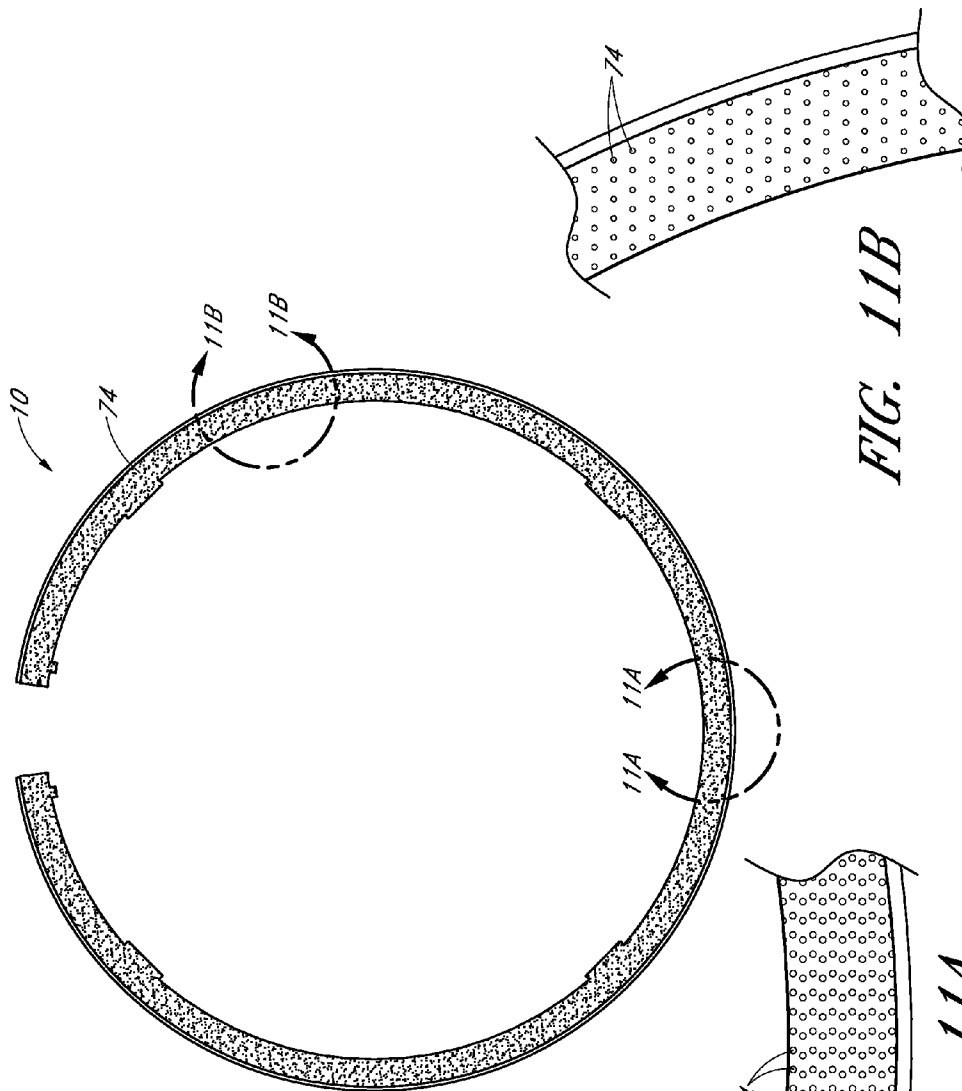

FIG. 11

FIG. 11B

FIG. 11A

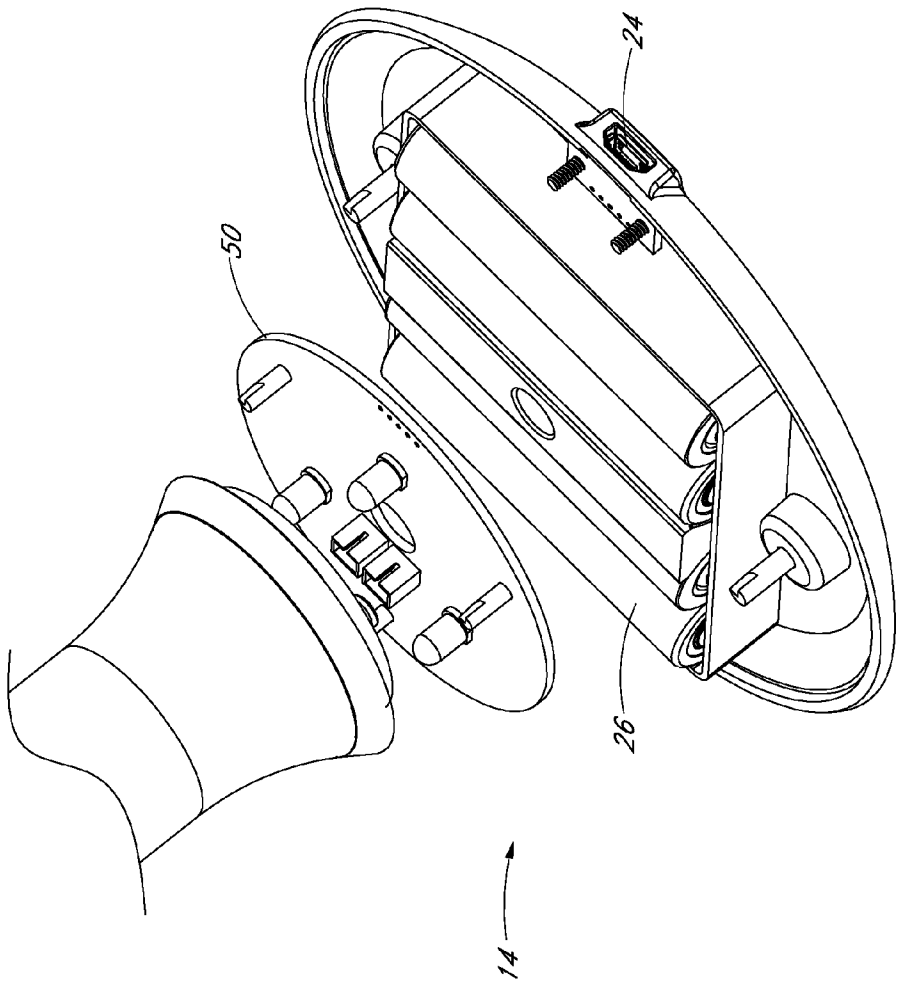

FIG. 12

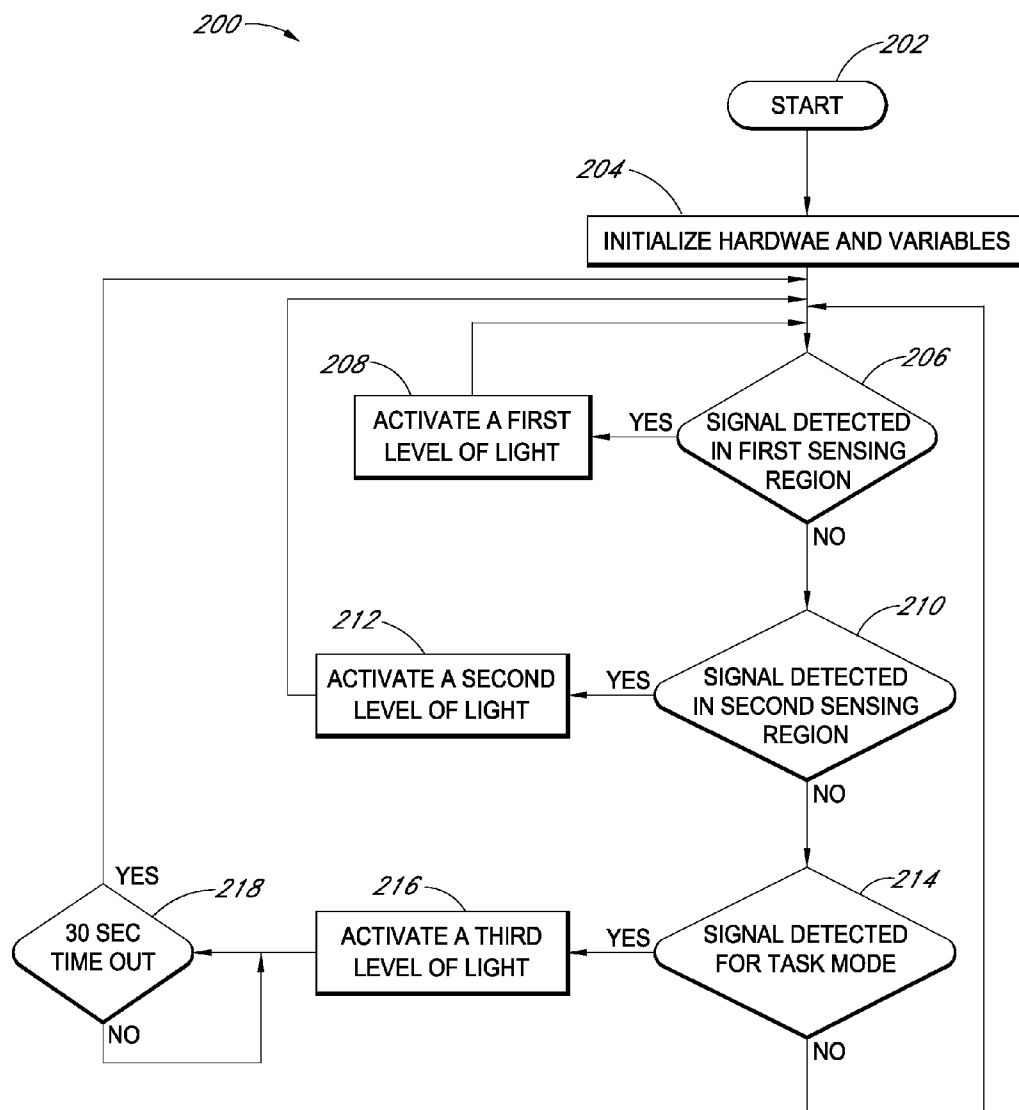

FIG. 13

## VANITY MIRROR

### CROSS-REFERENCE TO RELATED APPLICATIONS

**[0001]** This present application claims priority benefit under 35 U.S.C. §119(e) to U.S. Provisional Application No. 61/608,584, filed Mar. 8, 2012, entitled “VANITY MIRROR ASSEMBLY,” which is hereby incorporated by reference in its entirety.

### BACKGROUND

**[0002]** 1. Field

**[0003]** The present disclosure relates to reflective devices, such as mirrors.

**[0004]** 2. Description of the Related Art

**[0005]** Vanity mirrors are mirrors that are typically used for reflecting an image of a user during personal grooming, primping, cosmetic care, or the like. Vanity mirrors are available in different configurations, such as free-standing mirrors, hand-held mirrors, mirrors connected to vanity tables, bathroom wall mirrors, car mirrors, and/or mirrors attached to or produced by electronic screens or devices.

**[0006]** Many vanity mirrors distort the reflected image because of, for example, poor quality reflective surfaces, harsh light sources, and/or uneven distribution of light. Additionally, the light sources of conventional vanity mirrors are typically energy inefficient. Further, the light sources of conventional vanity mirrors are not adjustable or are difficult to effectively adjust.

### SUMMARY

**[0007]** In some embodiments, a mirror assembly comprises a base, a reflective face connected with the base, a sensor (e.g., a proximity sensor or a reflective type sensor), an electronic processor, and a light source. In some implementations, the sensor is configured to detect, and generate a signal indicative of, the distance between an object and the sensor. The electronic processor can be configured to receive the signal from the sensor and can control the light source, for example, by varying the quantity or quality of light emitted by the light source depending on the detected distance between the object and the sensor.

**[0008]** In some embodiments, a mirror assembly comprises a base, a reflection face, one or more light sources, and a light-conveying pathway such as a light pipe. In combination, the light sources and light pipe reflect substantially constant light along a length of the light pipe. For example, in certain embodiments, the light conveying pathway is generally disposed around some, substantially all, or all of a periphery of the reflection face.

**[0009]** Certain aspects of this disclosure are directed toward a mirror assembly. The mirror assembly can include a mirror coupled with the housing portion, and a light source disposed at a periphery of the mirror. The mirror assembly can include a light path, such as a light pipe, having a length and positioned around at least a portion of the periphery of the mirror. The mirror assembly can include a light scattering region, such as a plurality of light scattering elements disposed along the length of the light pipe. The light scattering elements can have a pattern density that varies depending, at least in part, on the distance along the light path from the light source. The light scattering elements can be configured to encourage a portion of the light impacting the light scattering

elements to be emitted out of the light path along a desired portion of the length of the light path. The amount of light scattering elements on the light path can vary depending, at least in part, on the distance along the light path from the light source. In certain embodiments, the pattern density can be less dense in a region generally adjacent the light source and more dense in a region spaced away from, or generally opposite from, the light source along the periphery of the mirror, thereby scattering the light to a greater degree as the intensity of the light diminishes further from the light source, and facilitating a substantially constant amount of light emitted along the length of the light pipe.

**[0010]** Any of the vanity mirror features, structures, steps, or processes disclosed in this specification can be included in any embodiment. The light scattering elements in the region generally adjacent the light source can be smaller compared to the light scattering elements in the region spaced from, or generally opposite from, or generally furthest from, the light source. The light source can be positioned near an upper portion of the mirror. The light pipe can be disposed along substantially all of the periphery of the mirror. The light source can emit light in a direction generally orthogonal to a standard viewing direction of the mirror. The light pipe can be generally circular and can include a first end and a second end. The light source can emit light into the first end, and another light source can emit light into the second end. In some embodiments, the light scattering elements can be generally uniformly distributed along at least a portion of the light pipe.

**[0011]** Certain aspects of this disclosure are directed toward a mirror assembly including a mirror coupled with a housing portion and one or more light sources disposed at a periphery of the mirror. The one or more light sources can be configured to emit light in a direction generally orthogonal to a primary viewing direction of the mirror. The light pipe can have a length and can be disposed along substantially all of the periphery of the mirror. The light pipe can be configured to receive light from the one or more light sources and distribute the light generally consistently along the length, thereby providing a generally constant level of illumination to the periphery of the mirror.

**[0012]** Any of the vanity mirror features, structures, steps, or processes disclosed in this specification can be included in any embodiment. The one or more light sources can include a first light source configured to project light in a first direction around the periphery of the mirror and a second light source configured to project light in a second direction around the periphery of the mirror. The one or more light sources can be two light sources. Each of the light sources can use less than or equal to about three watts of power. The one or more light sources can have a color rendering index of at least about 90. The one or more light sources can include light emitting diodes. The light pipe can be configured to transmit at least about 95% of the light emitted from the one or more light sources.

**[0013]** Certain aspects of this disclosure are directed toward methods of manufacturing a mirror assembly, such as any of the mirror assemblies disclosed in this specification. The methods can include coupling a mirror and a housing portion. The method can include disposing a light source at a periphery of the mirror. The method can include positioning a light pipe around at least a portion of the periphery of the mirror. The method can include disposing a plurality of light scattering elements along the length of a light pipe. In certain embodiments, the plurality of light scattering elements can

have a pattern density. The light scattering elements can be configured to encourage a portion of the light impacting the light scattering elements to be emitted out of the light pipe. The pattern density can be less dense in a region generally adjacent the light source, and the pattern density can be more dense in a region generally opposite from, spaced from, or furthest from, the light source along the periphery of the mirror, thereby facilitating a substantially constant amount of light emitted along the length of the light pipe. In certain embodiments, the method can include positioning the light source near an upper portion of the mirror. In certain embodiments, the method can include disposing the light pipe around substantially all of the periphery of the mirror. In certain embodiments, the method can include positioning the light source to emit light in a direction generally orthogonal to a main viewing direction of the mirror. In certain embodiments, the method can include positioning the light source to emit light into a first end of the light pipe and positioning another light source to emit light into a second end of the light pipe. In certain embodiments, the method can include disposing the light scattering elements in a generally uniform pattern along at least a portion of the light pipe.

**[0014]** Certain aspects of this disclosure are directed toward a mirror assembly having a housing portion, a mirror, one or more light sources, a proximity sensor, and an electronic processor. The mirror can be coupled with the housing portion. The one or more light sources can be disposed at a periphery of the mirror. The proximity sensor can be configured to detect an object within a sensing region. The proximity sensor can be configured to generate a signal indicative of a distance between the object and the proximity sensor. The electronic processor can be configured to generate an electronic signal to the one or more light sources for emitting a level of light that varies depending on the distance between the object and the sensor.

**[0015]** Any of the vanity mirror features, structures, steps, or processes disclosed in this specification can be included in any embodiment. The proximity sensor can be positioned generally near a top region of the mirror. The electronic processor can be configured to generate an electronic signal to the one or more light sources to deactivate if the proximity sensor does not detect the presence and/or movement of the object for a predetermined period of time. The proximity sensor can be configured to have increased sensitivity after the proximity sensor detects the object (e.g., by increasing the trigger zone distance, by increasing the sensitivity to movement within a trigger zone, and/or by increasing the time period until deactivation). The mirror assembly can include an ambient light sensor configured to detect a level of ambient light. In some embodiments, the sensing region can extend from about 0 degrees to about 45 degrees downward relative to an axis extending from the proximity sensor. The proximity sensor can be mounted at an angle relative to a viewing surface of the mirror. The mirror assembly can include a lens cover positioned near the proximity sensor. In certain embodiments, a front surface of the lens cover can be positioned at an angle relative to the proximity sensor. The mirror assembly can include a light pipe having a length and being disposed along substantially all of the periphery of the mirror. The light pipe can be configured to receive light from the one or more light sources and distribute the light generally consistently along the length, thereby providing a substantially constant level of illumination to the periphery of the mirror.

**[0016]** Certain aspects of this disclosure are directed toward a method of manufacturing a mirror assembly. The method can include coupling a mirror with a housing portion. The method can include disposing one or more light sources at a periphery of the mirror. The method can include configuring a proximity sensor to generate a signal indicative of a distance between an object and the proximity sensor. The method can include configuring an electronic processor to generate an electronic signal to the one or more light sources for emitting a level of light that varies depending on the distance between the object and the sensor.

**[0017]** Any of the vanity mirror features, structures, steps, or processes disclosed in this specification can be included in any embodiment. The method of manufacturing the mirror assembly can include positioning the proximity sensor generally near a top region of the mirror. The method can include configuring the electronic processor to generate an electronic signal to the one or more light sources to deactivate if the proximity sensor does not detect the object for a period of time. The method can include configuring the proximity sensor to have increased sensitivity after the proximity sensor detects the object. The method can include configuring an ambient light sensor to detect a level of ambient light. The method can include configuring the proximity sensor to detect an object within a sensing region extending from about 0 degrees to about 45 degrees downward relative to an axis extending from the proximity sensor. The method can include mounting the proximity sensor at an angle relative to a viewing surface of the mirror. The method can include positioning a lens cover near the proximity sensor. In certain embodiments, the method can include positioning a front surface of the lens cover at an angle relative to the proximity sensor. The method can include disposing a light pipe along substantially all of the periphery of the mirror. The light pipe can be configured to receive light from the one or more light sources and distribute the light generally consistently along the length, thereby providing a substantially constant level of illumination to the periphery of the mirror.

**[0018]** For purposes of summarizing the disclosure, certain aspects, advantages and features of the inventions have been described herein. It is to be understood that not necessarily any or all such advantages are achieved in accordance with any particular embodiment of the inventions disclosed herein. No aspects of this disclosure are essential or indispensable.

#### BRIEF DESCRIPTION OF THE DRAWINGS

**[0019]** The above-mentioned and other features of the mirror assembly disclosed herein are described below with reference to the drawings of certain embodiments. The illustrated embodiments are intended to illustrate, but not to limit the present disclosure. The drawings contain the following Figures:

**[0020]** FIG. 1 illustrates a perspective view of an embodiment of a mirror assembly.

**[0021]** FIG. 2 illustrates a front view of the embodiment of FIG. 1.

**[0022]** FIGS. 3 and 4 illustrate side views of the embodiment of FIG. 1.

**[0023]** FIG. 5 illustrates a top view of the embodiment of FIG. 1.

**[0024]** FIG. 6 illustrates a bottom view of the embodiment of FIG. 1.

**[0025]** FIG. 7 illustrates a rear view of the embodiment of FIG. 1.



[0026] FIG. 8A illustrates an exploded view of an embodiment of the mirror assembly.

[0027] FIG. 8B illustrates an exploded view of another embodiment of the minor assembly.

[0028] FIG. 9 illustrates an enlarged view of the embodiment of FIG. 8A showing a sensor assembly.

[0029] FIG. 10 illustrates an enlarged view of the embodiment of FIG. 8B showing a rear side of a sensor assembly.

[0030] FIG. 11 illustrates a light conveying pathway of the embodiment shown in FIG. 1.

[0031] FIGS. 11A-11B illustrate enlarged views of portions of the light conveying pathway shown in FIG. 11.

[0032] FIG. 12 illustrates an enlarged view of the embodiment of FIG. 1 showing a partially exploded view of a base portion.

[0033] FIG. 13 illustrates a block diagram of an embodiment of an algorithm that can be carried-out by components of the mirror assembly of FIG. 1.

#### DETAILED DESCRIPTION OF CERTAIN EMBODIMENTS

[0034] Certain embodiments of a minor assembly are disclosed in the context of a portable, free-standing vanity mirror, as it has particular utility in this context. However, the various aspects of the present disclosure can be used in many other contexts as well, such as wall-mounted minors, mirrors mounted on articles of furniture, automobile vanity minors (e.g., mirrors located in sun-visors), and otherwise. None of the features described herein are essentially or indispensable. Any feature, structure, or step disclosed herein can be replaced with or combined with any other feature, structure, or step disclosed herein, or omitted.

[0035] As shown in FIGS. 1-7, the minor assembly 2 can include a housing portion 8 and a visual image reflective surface, such as a mirror 4. The housing portion 8 can include a support portion 20, a shaft portion 12, and/or a base portion 14. The housing portion 8 can also include a pivot portion 16 connecting the support portion 20 and the shaft portion 12. Certain components of the housing portion 8 can be integrally formed or separately formed and connected together to form the housing portion 8. The housing 8 can include plastic, stainless steel, aluminum, or other suitable materials.

[0036] The minor assembly 2 can include one or more of the components described in connection with FIGS. 8A and 8B. FIG. 8B illustrates a minor assembly 102 including many components similar to the mirror assembly 2 components. The similar components include similar reference numbers in the 100s (e.g., minor 4 can be similar to minor 104).

[0037] The mirror 4 can include a generally flat or generally spherical surface, which can be convex or concave. The radius of curvature can depend on the desired optical power. In some embodiments, the radius of curvature can be at least about 15 inches and/or less than or equal to about 30 inches. The focal length can be half of the radius of curvature. For example, the focal length can be at least about 7.5 inches and/or less than or equal to about 15 inches. In some embodiments, the radius of curvature can be at least about 18 inches and/or less than or equal to about 24 inches. In some embodiments, the mirror 4 can include a radius of curvature of about 20 inches and a focal length of about 10 inches. In some embodiments, the mirror 4 is aspherical, which can facilitate customization of the focal points.

[0038] In some embodiments, the radius of curvature of the mirror 4 is controlled such that the magnification (optical

power) of the object is at least about 2 times larger and/or less than or equal to about 7 times larger. In certain embodiments, the magnification of the object is about 5 times larger. In some embodiments, the minor can have a radius of curvature of about 19 inches and/or about 7 times magnification. In some embodiments, the minor can have a radius of curvature of about 24 inches and/or about 5 times magnification.

[0039] As shown in FIG. 8A, the mirror 4 can have a generally circular shape. In other embodiments, the mirror 4 can have an overall shape that is generally elliptical, generally square, generally rectangular, or any other shape. In some embodiments, the mirror 4 can have a diameter of at least about 8 inches and/or less than or equal to about 12 inches. In some embodiments, the mirror 4 can have a diameter of about 8 inches. In certain embodiments, the mirror 4 can have a diameter of at least about 12 inches and/or less than or equal to about 16 inches. In some embodiments, the mirror 4 can include a thickness of at least about 2 mm and/or less than or equal to about 3 mm. In some embodiments, the thickness is less than or equal to about two millimeters and/or greater than or equal to about three millimeters, depending on the desired properties of the mirror 4 (e.g., reduced weight or greater strength). In some embodiments, the surface area of the mirror 4 is substantially greater than the surface area of the base 14. In other embodiments, the surface area of the image-reflecting surface of the mirror 4 is greater than the surface area of the base 14.

[0040] The mirror 4 can be highly reflective (e.g., has at least about 90% reflectivity). In some embodiments, the mirror 4 has greater than about 70% reflectivity and/or less than or equal to about 90% reflectivity. In other embodiments, the mirror 4 has at least about 80% reflectivity and/or less than or equal to about 100% reflectivity. In certain embodiments, the mirror has about 87% reflectivity. The mirror 4 can be cut out or ground off from a larger minor blank so that minor edge distortions are diminished or eliminated. One or more filters can be provided on the minor to adjust one or more parameters of the reflected light. In some embodiments, the filter comprises a film and/or a coating that absorbs or enhances the reflection of certain bandwidths of electromagnetic energy. In some embodiments, one or more color adjusting filters, such as a Makrolon filter, can be applied to the mirror to attenuate desired wavelengths of light in the visible spectrum.

[0041] The mirror 4 can be highly transmissive (e.g., nearly 100% transmission). In some embodiments, transmission can be at least about 90%. In some embodiments, transmission can be at least about 95%. In some embodiments, transmission can be at least about 99%. The mirror 4 can be optical grade and/or comprise glass. For example, the mirror 4 can include ultra clear glass. Alternatively, the mirror 4 can include other translucent materials, such as plastic, nylon, acrylic, or other suitable materials. The mirror 4 can also include a backing including aluminum or silver. In some embodiments, the backing can impart a slightly colored tone, such as a slightly bluish tone to the minor. In some embodiments, an aluminum backing can prevent rust formation and provide an even color tone. The mirror 4 can be manufactured using molding, machining, grinding, polishing, or other techniques.

[0042] The mirror assembly 2 can include one or more light sources 30 configured to transmit light. For example, as shown in FIG. 9, the minor assembly can include a plurality (e.g., two) of light sources 30. Various light sources 30 can be used. For example, the light sources 30 can include light

emitting diodes (LEDs), fluorescent light sources, incandescent light sources, halogen light sources, or otherwise. In some embodiments, each light source **30** consumes at least about 2 watts of power and/or less than or equal to about 3 watts of power. In certain embodiments, each light source **30** consumes about 2 watts of power.

**[0043]** In certain embodiments, the width of each light source can be less than or equal to about 10.0 mm. In certain embodiments, the width of each light source can be less than or equal to about 6.5 mm. In certain embodiments, the width of each light source can be less than or equal to about 5.0 mm. In certain embodiments, the width of each light source can be about 4.0 mm.

**[0044]** The light sources **30** can be configured to mimic or closely approximate natural light with a substantially full spectrum of light in the visible range. In some embodiments, the light sources **30** have a color temperature of greater than or equal to about 4500 K and/or less than or equal to about 6500 K. In some embodiments, the color temperature of the light sources **30** is at least about 5500 K and/or less than or equal to about 6000 K. In certain embodiments, the color temperature of the light sources **30** is about 5700 K.

**[0045]** In some embodiments, the light sources **30** have a color rendering index of at least about 70 and/or less than or equal to about 90. Certain embodiments of the one or more light sources **30** have a color rendering index (CRI) of at least about 80 and/or less than or equal to about 100. In some embodiments, the color rendering index is high, at least about 87 and/or less than or equal to about 92. In some embodiments, the color rendering index is at least about 90. In some embodiments, the color rendering index can be about 85.

**[0046]** In some embodiments, the luminous flux can be at least about 80 lm and/or less than or equal to about 110 lm. In some embodiments, the luminous flux can be at least about 90 lm and/or less than or equal to about 100 lm. In some embodiments, the luminous flux can be about 95 lm.

**[0047]** In some embodiments, the forward voltage of each light source can be at least about 2.4 V and/or less than or equal to about 3.6 V. In some embodiments, the forward voltage can be at least about 2.8 V and/or less than or equal to about 3.2 V. In some embodiments, the forward voltage is about 3.0 V.

**[0048]** In some embodiments, the illuminance at an outer periphery of the sensing region is at least about 500 lux and/or less than or equal to about 1000 lux. The illuminance level can be higher at a distance closer to the face of the mirror. In some embodiments, the illuminance at an outer periphery of the sensing region is about 700 lux. In some embodiments, the illuminance at an outer periphery of the sensing region is about 600 lux. In some embodiments, the sensing region extends about 8 inches away from the face of the mirror. Many other sensing regions can also be utilized, some of which are described below. In certain variants, the mirror assembly **2** can include a dimmer to adjust the intensity of the light.

**[0049]** In some embodiments, the light sources **30** are configured to provide multiple colors of light and/or to provide varying colors of light. For example, the light sources **30** can provide two or more discernable colors of light, such as red light and yellow light, or provide an array of colors (e.g., red, green, blue, violet, orange, yellow, and otherwise). In certain embodiments, the light sources **30** are configured to change the color or presence of the light when a condition is met or is about to be met. For example, certain embodiments momen-

tarily change the color of the emitted light to advise the user that the light is about to be deactivated.

**[0050]** As shown in FIG. 9, the light sources can be positioned near the uppermost region of the mirror assembly **2**. In other embodiments, the light sources **30** are positioned at other portions of the mirror assembly **2**, such as, within the light pipe **10** or directly mounted to the mirror **4** at spaced-apart intervals around the periphery of the mirror **4**. For example, the light sources **30** can be positioned around some, substantially all, or all of the periphery of the mirror **4**. In certain embodiments, the light sources **30** is separate from and does not connect with the mirror assembly **2**.

**[0051]** The light sources **30** can be positioned in various orientations in relation to each other, such as side-by-side, back-to-back, or otherwise. In certain embodiments, the light sources **30** can be positioned to emit light in opposing directions. For example, as shown in FIG. 9, a first light source **30a** projects light in a first direction (e.g., clockwise) around the periphery of the mirror **4**, and a second light source **30b** projects light in a second direction (e.g., counter-clockwise) around the periphery of the mirror **4**. In certain embodiments, the light sources **30** can be positioned to emit light generally orthogonally to the viewing surface of the mirror assembly **2**. In certain embodiments, the light sources **30** can be positioned to emit light tangentially in relation to the periphery of the mirror **4**.

**[0052]** The mirror assembly **2** can include a mechanism to actively or passively dissipate, transfer, or radiate heat energy away from the light sources **30**, such as a fan, vent, and/or one or more passive heat dissipating or radiating structures **34**. The support portion **20** can include a receiving portion **22** near an upper region of the mirror assembly **2** for receiving a heat dissipating structures **34**. The heat dissipating structures **34** can be formed of materials with a high rate of heat conduction, such as aluminum or steel, to help remove heat from the mirror assembly that is generated by the light sources **30**. Many other heat dissipating materials, such as copper or brass, can be used.

**[0053]** The heat dissipating structures **34** can dissipate heat created by the light sources **30** and/or conduct electricity to the light sources. The heat dissipating structures **34** that both dissipate heat and conduct electricity to the light sources **30** reduce the total number of necessary components. In some embodiments, as illustrated, the heat dissipating structure **34** can include one or more components that are generally comparatively long in one dimension, generally comparatively wide in another dimension, and generally comparatively narrow in another dimension, to provide a large surface area over a thin surface to conduct heat efficiently through the heat dissipating structure **34** and then readily transfer such heat into the surrounding air and away from heat-sensitive electronic components in the mirror assembly. For example, the length of the heat dissipating structure **34** can be substantially greater than the width of the heat dissipating structure **34**, and the width of the heat dissipating structure **34** can be substantially greater than the thickness.

**[0054]** The heat dissipating structures **34** can be electrically connected circuit boards and/or provides electric power and signals to the light sources **30** attached directly or indirectly thereto. In some embodiments, the temperature of the light sources **30** with the heat dissipating structures **34** is less than or equal to about 70° F. In some embodiments, the temperature of the light sources **30** with the heat dissipating structures **34** is between about 50° F. and 60° F.

[0055] As shown in FIG. 8A, the heat dissipating structure 34 can be a single structure including a support panel 34c positioned substantially parallel to the mirror 4. In some embodiments, the support panel 34c is a circuit board. The heat dissipating structure 34 can also include one or more fins mounted to the support panel 34c. As shown in FIG. 8A, the heat dissipating structure 34 can include two fins 34a, 34b. The fins 34a, 34b can be positioned between the support panel 34c and the mirror 4. The fins 34a, 34b can also be positioned such that the first ends of each of the fins 34a', 34b' are closer together than the second ends of the fins 34a'', 34b'' (e.g., V-shaped). The fins 34a, 34b can be directly or indirectly connected to the light sources 30. For example, each fin 34a, 34b can receive a light source 30.

[0056] As shown in FIG. 8B, the heat dissipating structures 134a, 134b can be separate components. Similar to FIG. 8A, the heat dissipating structures 134a, 134b can be positioned such that the first ends of each of the structures 134a', 134b' are closer together than the second ends of the fins 134a'', 134b'' (e.g., generally V-shaped). The structures 134a, 134b can be directly or indirectly connected to the light sources 130. For example, each of the structures 134a, 134b can receive a light source 130.

[0057] FIG. 10 shows a rear side of the minor assembly 102 without a rear cover portion 118. The second end of each of the heat dissipating structures 134a'', 134b'' can be positioned between the first end 140a and the second end 140b of the light pipe and on either side of the sensor assembly 128. The heat dissipating structures 134a, 134b can be positioned behind the support structure 120. For example, the heat dissipating structures 134a, 134b can be positioned between a circuit board 170 and the rear cover portion (not shown). The support portion 120 can also include one or more clasps 172 or other structures for engaging the circuit board 170.

[0058] The support portion 20 can support the minor 4 and a light conveying structure, such as a light pipe 10, positioned around at least a portion of a periphery of the minor 4. In some embodiments, the light pipe 10 is positioned only along an upper portion of mirror 4 or a side portion of the mirror 4. In other embodiments, the light pipe 10 extends around at least a majority of the periphery of the mirror 4, substantially the entire periphery of the mirror 4, or around the entire periphery of the mirror 4. As shown in FIG. 8A, the support portion 20 can include a structure, such as a ridge 21, which can support the light pipe 10 (e.g., a portion of the light pipe 10 can be disposed along the ridge 21).

[0059] Some or all of the light from the light sources 30 can be transmitted generally toward, or into, the light pipe 10. For example, as shown in FIG. 8A, the light pipe 10 can include ends 40a, 40b, and the light sources 30 can emit light into one or both of the ends 40a, 40b of the light pipe 10. The light sources 30 can be positioned such that the light is emitted generally toward a user facing the viewing surface of the minor assembly 2. For example, some or all of the light from the light sources 30 and/or the light pipe 10 can be emitted toward, and reflected off of, another component before contacting the user. In some embodiments, the light sources 30 are positioned behind the minor 4 (e.g., creating a backlighting effect of the mirror 4). In some embodiments, the light sources 30 are positioned (e.g., by tilting) such that light emitted from the light sources 30 contacts the viewing surface of the mirror assembly 2 at an angle, such as an acute angle. In some embodiments, the light sources 30 are positioned

such that light emitted from the light sources 30 contacts the viewing surface of the mirror assembly 2 at an obtuse angle.

[0060] When installed on the support member 20, the light pipe 10 has a radial width and an axial depth. Some variants have a radial width that is greater than or equal to the axial depth. In certain implementations, the light pipe 10 is configured to provide adequate area for the reflecting surface of the minor 4 and to provide sufficient area for light to be emitted from the light pipe 10, as will be discussed in more detail below. For example, the ratio of the radial width of the light pipe 10 to the radius of the mirror 4 can be less than or equal to about: 1/5, 1/15, 1/30, 1/50, values in between, or otherwise.

[0061] As shown in FIG. 8A, the light pipe 10 can be substantially circularly shaped. The light pipe 10 can include a gap 44, and the sensor assembly 28 and/or the light sources 30 can be positioned in the gap 44. In some embodiments, the light pipe 10 can be substantially linearly shaped, or the light pipe 10 has a non-linear and non-circular shape. The light pipe 10 can include acrylic, polycarbonate, or any other clear or highly transmissive material. The light pipe 10 can be at least slightly opaque.

[0062] The light can pass along and through a portion of the light pipe 10 and/or emit from the light pipe 10 via an outer face 42 of the light pipe 10. In some embodiments, the light pipe 10 is configured to transmit at least about 95% of the light emitted from the light sources 30. The light sources 30 can be configured, in combination with light pipe 10, to emit light generally around the periphery of the minor 4. The light pipe 10 can be configured to disperse light from the light sources 30 through the light pipe 10. The light sources 30 and the light pipe 10 can be configured such that the amount of light emitted from the outer face 42 is substantially constant along the length of the light pipe 10. Many different ways of achieving a substantially constant intensity of conveyed light around the light pipe 10 can be used.

[0063] The support portion 20 and/or the light pipe 10 can include features to facilitate generally even or uniform diffusion, scattering, and/or reflection of the light emitted by the light sources 30 around the periphery of the minor. For example, the support portion 20 and/or light pipe 10 can include an irregular anterior and/or posterior surface that is molded in a non-flat and/or non-planar way, etched, roughened, painted, and/or otherwise surface modified. The light scattering elements can be configured to disperse a substantially constant amount of light along the periphery of the mirror 4. These features can help achieve high energy-efficiency, reducing the total number of light sources necessary to light substantially the entire periphery of the minor and reducing the temperature of the mirror assembly 2.

[0064] The light pipe 10 can comprise a generally translucent material with varying degrees of scattering, such that the minimum amount of scattering occurs in a region near the light source(s) and the maximum scattering occurs in a region of the light pipe 10 that is located furthest from the light source(s). The light pipe 10 can comprise a region configured to scatter light in a varying manner. In some embodiments, the light conveying pathway or light pipe 10 can comprise a varying, non-constant, non-smooth anterior, posterior, and/or interior surface formed from any suitable process, such as molding, etching, roughening painting, coating, and/or other methods. In some embodiments, one or more surface irregularities can be very small bumps, protrusions, and/or indentations.

**[0065]** In some embodiments, light passing through the light pipe **10** can be scattered at a plurality of different intensity levels, depending on the location of the light within the light pipe **10**. For example, light at a first location on the light pipe **10** can be scattered at a first intensity level, light at a second location on the light pipe **10** can be scattered at a second intensity level, and light at a third location on the light pipe **10** can be scattered at a third intensity level, with the third intensity level being more than the second intensity level, and the second intensity level being more than the first intensity level, etc. Many other levels of scattering and many ways of spatially increasing or decreasing scattering can be used instead of or in addition to providing macro scattering elements, such as spatially varying a level of die or a frosting effect within the material of the light pipe **10**, or by spatially varying scattering particles embedded within the material, or by spatially varying a surface pattern on one or more outside surfaces of the material.

**[0066]** The light pipe **10** can include a surface pattern, such as light scattering elements **74** (e.g., a dot pattern) as shown in FIG. **11**. The light scattering elements **74** can be configured to encourage a portion of the light passing through the light pipe **10** to exit the outer face **42** of the light pipe **10**, thereby generally illuminating the user in a generally even or generally uniform manner. The light scattering elements can be configured such that the light intensity emitted from the outer face **42** of the light pipe **10** is substantially constant along a substantial portion of, or virtually the entirety of, the length of the light pipe **10**. Accordingly, the user can receive generally constant light volume or intensity around the periphery of the mirror **4**. For example, the light scattering elements can include one or more of varied density, irregular patterns, or varied sizes.

**[0067]** As shown in FIG. **11**, the light scattering elements **74** can be less dense near the light sources **30** (FIG. **11B**), and become increasingly dense as a function of increased distance from the light sources **30** (FIG. **11A**). Such a configuration can, for example, reduce the amount of light that is scattered or reflected (and thus exits the outer face **42**) in areas having generally increased light volume or light intensity, such as portions of the light pipe **10** that are near the light sources **30**. Further, such a configuration can encourage additional scattering or reflection (and thus increase the amount that exits the outer face **42**) in areas having generally decreased light volume or intensity, such as portions of the light pipe **10** that are spaced away from the light sources **30**. Accordingly, the mirror assembly **2** can avoid bright areas at some portions of the periphery of the mirror **4** and dark areas at other portions. The mirror assembly **2** can have a substantially constant amount of light emitted along some, substantially all, or all of the periphery of the mirror **4**.

**[0068]** The light scattering elements can be dispersed in an irregular pattern, such that the light scattering pattern in a first region is different than a light scattering pattern in a second region. A distance between a first light scattering element and a second light scattering element can be different than a distance between a first light scattering element and a third light scattering element.

**[0069]** The sizes (e.g., the diameter) of the light scattering elements can be varied. In some variants, the light scattering elements near the light sources **30** can have a smaller size when compared to light scattering elements that are farther from the light sources **30**. For example, the light scattering elements can include a smaller diameter near the light sources

**30** and become increasingly larger as a function of distance from the light sources **30**. Such a configuration allows substantially even reflection of light to the outer surface **42**. In certain embodiments, each light scattering element has a diameter of less than or equal to about one millimeter. In some embodiments, the light scattering elements each have a diameter greater than or equal to about one millimeter.

**[0070]** In some embodiments, the light scattering elements can be generally circular. In some embodiments, the light scattering elements have other shapes, such as generally square, generally rectangular, generally pentagonal, generally hexagonal, generally octagonal, generally oval, and otherwise. In certain embodiments, the pattern in the light pipe **10** is a series of lines, curves, spirals, or any other pattern. In certain embodiments, the light scattering elements are white. The light scattering elements can be dispersed such that the light pipe **10** appears frosted. In some embodiments, the light scattering elements are not easily visible to the user. For example, the light pipe **10** can be slightly opaque to conceal the appearance of the surface pattern. In some embodiments, the light scattering elements are visible to the user, the light pipe **10** can be clear to show the general color and pattern of the surface elements.

**[0071]** The light pipe **10** can include a reflective material to achieve high reflectivity. For example, the light pipe **10** can include a reflective backing material along the rear side of the light pipe. In some embodiments, the reflective material can reflect at least about 95% of light. In some embodiments, the reflective material reflects about 98% of light. The reflective material can be optically reflective paper.

**[0072]** As shown in FIG. **8B**, the mirror assembly **102** can also include a diffuser **156**. The diffuser **156** can be positioned on the surface of the light pipe **110** and/or around the periphery of the mirror **104**. For example, the diffuser **156** can be positioned between the light pipe **10** and the user to provide a diffuse, scattered light source, not a focused, sharp light source, which would be less comfortable on the user's eyes. In some embodiments, the transmissivity of the diffuser is substantially constant around its perimeter or circumference. In some embodiments, the diffuser **156** can surround a majority of the periphery of the mirror **104**, substantially the entire periphery of the mirror, or the entire periphery of the mirror. As shown in FIG. **8B**, the diffuser **156** can surround generally the same portion of the periphery of the mirror **104** as the light pipe **110**. The diffuser **156** can also include an opening **160** for the sensor assembly **128** and/or a receiving portion **157** for receiving the mirror **104**. The diffuser **156** can include an at least partially opaque material. For example, the diffuser **156** can include optical grade acrylic.

**[0073]** The diffuser **156** can include an irregular anterior and/or posterior surface formed from etching, roughening, painting, and/or other methods of surface modification. For example, the diffuser **156** can include a pattern of light scattering elements (not shown) created using any of the methods discussed herein. The light scattering elements can be modified to include any of the shapes and/or sizes discussed in connection with the light pipe **10**.

**[0074]** The light scattering elements can be configured to create soft light by further scattering the light. For example, the light scattering elements can include a plurality of dots having the same diameter or different diameters. In some embodiments, the light scattering elements can be evenly

dispersed across the diffuser 156. In other embodiments, the light scattering elements can be randomly dispersed across the diffuser 156.

[0075] Returning to FIG. 8A, a cover member 6 can cover the sensor assembly 28 and the light sources 30. The cover member 6 can be clear and polished acrylic, polycarbonate, or any other suitable material. On the rear side, the housing 8 can include a rear cover portion 18, which can be configured to at least partially enclose one or more components of the minor assembly 2. The rear cover portion 18 can include an aperture 32 through which the pivot portion 16 can extend to engage with the support portion 20. The rear cover portion 18 can also include one or more vents to further reduce the temperature. As shown in FIG. 8B, the minor assembly 102 can include a gasket 164 positioned between the support portion 120 and rear cover portion 118.

[0076] As previously noted, the pivot portion 16 can connect the support portion 20 and the shaft portion 12. The pivot portion 16 allows the mirror 4 to be pivoted in one or more directions (e.g., up, down, right, left, and/or in any other direction). For example, the pivot 16 can include a ball joint, one or more hinges, or otherwise.

[0077] The support portion 20 and the mirror 4 can be adjustable (e.g., slidably movable and/or rotatable) along an axis generally parallel to the surface of the mirror 4 and to the ground and/or along an axis generally parallel to the surface of the mirror 4 and perpendicular to the ground. For example, the shaft portion 12 can be adjustable (e.g., slidably movable and/or rotatable) along an axis generally parallel to the surface of the mirror 4 and perpendicular to the ground. The support portion 20 and the mirror 4 can also be rotatable along an axis generally perpendicular from the surface of the mirror 4 (e.g., rotatable about the center of the mirror 4). The housing portion 8 can also include additional pivot portions, such as along the shaft portion 12.

[0078] To adjust the height of the minor assembly 2, the shaft portion 12 can be configured to translate generally perpendicular to the ground when the minor assembly 2 is positioned on the base 14. In some embodiments, the height of the shaft portion 12 can be adjusted within a range of at least about three inches and/or within a range less than four inches. In some embodiments, the height of the shaft portion 12 can be adjusted within about a four inch range. In some embodiments, the height of the shaft portion 12 can be adjusted within about a three inch range.

[0079] The shaft portion 12 can include a first shaft portion 12a and a second shaft portion 12b. The shaft portions 12a, 12b can be configured to adjustably engage each other, thereby allowing the user to select and maintain the mirror assembly 2 at a desired height. For example, the first shaft portion 12a can include one or more biased adjustment structures, such as spring-loaded retractable pegs (not shown), and the second shaft portion 12b can include one or more corresponding adjustment structures, such as notches (not shown). The pegs of the first shaft portion 12a can engage (e.g., snap into) with the notches of the second shaft portion 12b to control provide articulating adjustment of the height of the minor assembly 2.

[0080] In some embodiments, the first shaft portion 12a and the second shaft portion 12b can form an interference fit. This applied pressure allows the first shaft portion 12a and the second shaft portion 12b to be stationary relative to each other (e.g. hold the support portion 20 in desired height) without external force being applied. However, the applied pressure

between the shaft portions 12a and 12b can be controlled so that when the user wants to adjust the height of the support portion 20, the pressure can be overcome and shaft portions 12a and 12b can move relative to each other. For example, the amount of force required to downwardly or upwardly adjust the height or effective length of the shaft portion 12 can be greater than the downward force of gravity induced by the mass of the minor assembly and upper shaft portion but generally less than or equal to a natural human adjustment force for an appliance, such as less than or equal to about 3 or about 4 pounds. The sliding or adjustment of the height or effective length of the shaft components can be configured to stop virtually immediately when the user's adjustment force stops, without requiring further adjustments or securing structure to stop the sliding or to secure the components of the shaft portion against further unintended movement or change in height or length. The applied pressure can also simulate a dampening effect during movement of the shaft portions 12a and 12b.

[0081] The shaft portion 12 can also include a constraining member, such as ring member, that dampens or prevents the first shaft portion 12a from moving relative to the second shaft portion 12b. For example, certain variants of the ring member threadably engage with the second shaft portion 12b, thereby radially compressing the second shaft portion 12b against the first shaft portion 12a, which in turn inhibits the first shaft portion 12a from translating relative to the second shaft portion 12b. In certain implementations, loosening the ring member allows the user to adjust the height of the shaft portion 12, while tightening the ring member secures the first shaft portion 12a to the second shaft portion 12b.

[0082] In some embodiments, the shaft portion 12 includes a connector, such as a set-screw (not shown), which can be positioned generally perpendicular to the first shaft portion 12a. The second shaft portion 12b can include an opening (not shown) through which the screw member can extend. In certain implementations, when the set-screw is loosened, the first shaft portion 12a can be adjusted relative to the second shaft portion 12b. Tightening the screw member until it contacts the first shaft portion 12a can inhibit or prevent the first shaft portion 12a from moving relative to the second shaft portion 12b.

[0083] As shown in FIG. 8B, the shaft portion 112 can include one or more biasing members 154, such as springs (e.g., spiral coil springs, wave springs, conical springs, or otherwise). In certain variants, the one or more biasing members 154 are configured to facilitate adjustment of the height of the shaft portion 112. For example, the one or more biasing members 154 can reduce the amount of vertical force a user must exert to raise the height of the minor 104 relative to the base 114. The biasing members can be positioned in a lumen of the shaft portion 112.

[0084] The shaft portion 12 can include plastic, stainless steel, aluminum, or other suitable materials. The first shaft portion 12a can also include compressible materials, such as rubber, nylon, and plastics, on at least a portion of its outer surface that press against the inner surface of the second shaft portion 12b when the first shaft portion 12a is inserted into the second shaft portion 12b.

[0085] A portion of the support portion 20 can be cantilevered outward from the longitudinal axis of the shaft portion 12. Such a configuration can impart a moment of force on the minor assembly 2, which, if uncompensated for, could lead to tipping. The base portion 14 can also be configured to coun-

teract such a moment. For example, the base portion 14 can include a weight that is sufficient to reduce substantially the likelihood of tipping of the mirror assembly 2.

[0086] The base 14 and/or other portions of the minor assembly 2 can be generally balanced in mass distribution such that the center of mass of the mirror assembly 2 is generally positioned near the shaft 12 and/or near the base 14. The base portion 14 can weigh at least about 2 lbs., 4 lbs., 6 lbs., 8 lbs., 10 lbs., values in between, or otherwise. The base portion 14 can also include one or more supporting feet or be configured to be semi-permanently mountable (e.g., to be mounted to a countertop with one or more fasteners).

[0087] In some embodiments, as illustrated, the base portion 14 can have a generally curved outer surface. For example, a horizontal cross-section of the base at a plurality of points along its height can be generally circular or generally elliptical. In the illustrated embodiment, the base portion 14 is generally conical, such as generally frusto-conical. The outer surface of the base can be generally smooth, generally tapered and/or generally sloping, as illustrated, and/or present a virtually entirely continuous surface generally circumscribing the periphery of the base 14. The horizontal cross-sectional area or diameter at the top of the base 14 generally can be about the same as the horizontal cross-sectional area or diameter of the bottom of the shaft portion 12. The horizontal cross-sectional area of the base 14 can generally continuously increase from the top region of the base 14 to the bottom region of the base 14. For example, a horizontal cross-sectional area or diameter at the bottom region of the base 14 can be substantially larger than a horizontal cross-sectional area or diameter at the top region of the base 14 (e.g., at least about two or at least about three times larger), which is an example of a base 14 that can help resist tipping of the minor. In some embodiments, as illustrated, the distance along the shaft portion 12 from the bottom of the mirror portion to the top of the base portion can be generally about the same as the height of the base portion 14.

[0088] As discussed in further detail below, the base portion 14 can include a battery (e.g., a rechargeable battery). The weight and positioning of the battery can also reduce the chances of tipping of the mirror assembly 2. In some embodiments, the battery can deliver power to the light sources for at least about ten minutes per day for about thirty days. The battery 26 can be recharged via a port 24 (e.g., a universal serial bus (USB) port or otherwise), as shown in FIG. 12. The port 24 can be configured to permanently or removably receive a connector coupled with a wire or cable (not shown). The port 24 can also be configured to allow electrical potential to pass between the batteries 26 with a power source via the connector. The port 24 may be used to program or calibrate different operations of the minor illumination or object sensing when connect to a computer. Other charging methods can be used, such as via conventional electric adapter to be plugged in to an electric outlet.

[0089] The mirror assembly 2 can include an indicator device configured to issue a visual, audible, or other type of indication to a user of the mirror assembly 2 regarding a characteristic of the mirror assembly 2, the user, and/or the relationship between the mirror assembly 2 and the user. For example, the indicator can indicate on/off status, battery levels, imminent deactivation, and/or certain mode of operation. The indicator can be used for other purposes as well.

[0090] The color of the indicator light can vary depending on the indication. For example, the indicator can emit a green

light when the minor assembly is turned on and/or a red light when the battery is running low.

[0091] As shown in FIG. 1, the indicator 58 can ring-shaped and positioned around an upper portion of the base portion 14. The indicator 58 can take on any other shape and be positioned around the support portion 20, along the base portion 14, or on any other location on the mirror assembly 2.

[0092] The controller 50 controls the operation of a light sources 30. The controller 50 can be disposed in the base 14 and can include one or a plurality of circuit boards (PCBs), which can provide hard wired feedback control circuits, a processor and memory devices for storing and performing control routines, or any other type of controller.

[0093] The mirror assembly 2 can include a sensor assembly 28, as shown in FIGS. 2A and 9. The sensor assembly 28 can be positioned near an upper region of the minor assembly 2 (e.g., the top of the minor). For example, the sensor assembly 28 can be positioned in the gap 44 in the light pipe 10. The sensor assembly 28 can also be recessed from the front surface of the minor assembly 2. Alternatively, the sensor assembly 28 can disposed along any other portion of the mirror assembly 2 or not positioned on the mirror assembly 2. For example, the sensor assembly 28 can be positioned in any location in a room in which the minor assembly 2 sits. The sensor assembly 28 can include a proximity sensor or a reflective-type sensor. For example, the sensor 28 can be triggered when an object (e.g., a body part) is moved into, and/or produces movement within, a sensing region.

[0094] The sensor assembly 28 can include a transmitter and a receiver. The transmitter 36 can be an emitting portion (e.g., electromagnetic energy such as infrared light), and the receiver 38 can be a receiving portion (e.g., electromagnetic energy such as infrared light). The beam of light emitting from the light emitting portion 36 can define a sensing region. In certain variants, the transmitter can emit other types of energy, such as sound waves, radio waves, or any other signals. The transmitter and receiver can be integrated into the same sensor or configured as separate components.

[0095] In some embodiments, the light emitting portion 36 can emit light in a generally perpendicular direction from the front face of the mirror assembly. In some embodiments, the light emitting portion 36 emits light at a downward angle from a perpendicular to the front face of the minor assembly by at least about 5 degrees and/or less than or equal to about 45 degrees. In some embodiments, the light emitting portion 36 emits light at a downward angle from a perpendicular to the front face of the minor assembly by at least about 15 degrees and/or less than or equal to about 60 degrees. In certain embodiments, the light emitting portion 36 emits light at a downward angle of about 15 degrees.

[0096] In some embodiments, the sensor assembly 28 can detect an object within a sensing region. In certain embodiments, the sensing region can have a range from at least about 0 degrees to less than or equal to about 45 degrees downward relative to an axis extending from the sensor assembly 28, and/or relative to a line extending generally perpendicular to a front surface of the sensor assembly, and/or relative to a line extending generally perpendicular to the front face of the mirror and generally outwardly toward the user from the top of the mirror assembly. In certain embodiments, the sensing region can have a range from at least about 0 degrees to less than or equal to about 25 degrees downward relative to any of these axes or lines. In certain embodiments, the sensing

region can have a range from at least about 0 degrees to less than or equal to about 15 degrees downward relative to any of these axes or lines.

[0097] In some embodiments, the sensing region can be adjusted by mounting the sensor assembly 28 at an angle. In certain embodiments, the sensor assembly 28 can be mounted such that the front surface of the sensing assembly 28 can be generally parallel or coplanar with a front surface of mirror 4. In certain embodiments, the sensor assembly 28 can be mounted such that the front surface of the sensing assembly 28 can be at an angle relative to the front surface of the mirror.

[0098] In some embodiments, the sensing region can be adjusted by modifying one or more features of the cover member 6. In certain embodiments, the cover member 6 can include a lens material. In certain embodiments, the cover member 6 can include a generally rectangular cross-section. In certain embodiments, the cover member 6 can include a generally triangular cross-section. In certain embodiments, the cover member 6 can include a front surface generally parallel or coplanar with a front surface of the mirror 4. In certain embodiments, the cover member 6 can include a front surface at an angle relative to the front surface of the mirror 4. In certain embodiments, the front surface of the cover member 6 can be positioned at an angle relative to the sensor assembly 28.

[0099] In some embodiments, the sensing area generally widens as the front surface of the cover member 6 moves from the configuration generally parallel or coplanar with the front surface of the mirror 4 to the configuration at an angle relative to the front surface of the mirror 4. In certain embodiments, when the front surface of the cover member 6 is generally parallel or coplanar with the front surface of the mirror, the sensing region can have a range from about 0 degrees to about 15 degrees downward relative to the axis extending generally from the sensor assembly 28 and/or generally perpendicular to the front surface of the sensor assembly. In certain embodiments, when the front surface of the cover member 6 is at an angle relative to the front surface of the mirror 4, the sensing region can have a range from about 0 degrees to about 25 degrees downward relative to the axis extending generally from the sensor assembly 28 and/or generally perpendicular to the front surface of the sensor assembly.

[0100] The sensor assembly 28 may only require enough power to generate a low power beam of light, which may or may not be visible to the human eye. Additionally, the sensor assembly 28 can operate in a pulsating mode. For example, the light emitting portion 36 can be powered on and off in a cycle such as, for example, for short bursts lasting for any desired period of time (e.g., less than or equal to about 0.01 second, less than or equal to about 0.1 second, or less than or equal to about 1 second) at any desired frequency (e.g., once per half second, once per second, once per ten seconds). Cycling can greatly reduce the power demand for powering the sensor assembly 28. In operation, cycling does not degrade performance in some embodiments because the user generally remains in the path of the light beam long enough for a detection signal to be generated.

[0101] If the receiving portion 38 detects reflections (e.g., above a threshold level) from an object within the beam of light emitted from the light emitting portion 36, the sensor assembly 28 sends a signal to the controller to activate a light source.

[0102] The sensor assembly 28 can send different signals to the controller 50 based on the amount of light reflected back

toward the receiver 38. For example, the sensor assembly 28 is configured such that the amount of light emitted by the light sources 30 is proportional to the amount of reflected light, which can indicate the distance between the mirror 4 and the user. In certain variants, if the user is in a first sensing region, then the controller causes the one or more light sources 30 to activate from an off state or to emit a first amount of light. If the user is in a second sensing region (e.g., further away from the sensor assembly 28 than the first sensing region), then the controller causes the one or more light sources 30 to emit a second amount of light (e.g., less than the first amount of light).

[0103] The controller 50 can trigger at least two different levels of brightness from the light sources 30, such as brighter light or dimmer light. For example, if the user is anywhere in a first sensing region, then the controller 50 signals for bright light to be emitted; if the user is anywhere in a second sensing region, then the controller 50 signals for dim light to be emitted.

[0104] The controller 50 can also trigger more than two brightness levels. In certain implementations, the level of emitted light is related (e.g., linearly, exponentially, or otherwise) to the distance from the sensor to the user. For example, as the user gets closer to the sensor assembly 28, the one or more light sources 30 emit more light. Alternatively, the minor assembly 2 can be configured to emit more light when the user is further away from the sensor assembly 28, and less light as the user moves closer to the sensor assembly 28.

[0105] The sensor assembly 28 can include two light emitting portions 36a and 36b. Each transmitter 36a, 36b emits a cone of light with proper shielding or guiding on the transmitters 36a and 36b, which defines the detection zones of the sensors (subject to the nominal range of the sensors 28). The area in which the two cones overlap creates a primary sensing region, and areas in which the two cones emit light but do not overlap create a secondary sensing region. If a user is detected in the primary sensing region, then the sensor assembly 28 sends an appropriate signal to the controller 50, which triggers a first level of light from the light sources 30. If a user is detected in the secondary sensing region, then the sensor assembly 28 sends an appropriate signal to the controller 50, which activates a second level of light from the light sources 30. In some embodiments, the first level of light is brighter than the second level of light. In other embodiments, the second level of light is brighter than the first level of light. In some embodiments, the sensor assembly 28 defines more than two sensing regions and triggers more than two levels of light.

[0106] As shown in FIG. 9, the light emitting portions 38 can be positioned generally along the same horizontal plane (e.g., relative to the ground). The sensor assembly 28 can issue an appropriate signal to the controller 50, which can trigger brighter light when the user is within a first sensing region, directly in front of the sensor assembly 28. The sensor assembly can trigger dimmer light when the user is within a second sensing region, in the periphery of the minor assembly 2.

[0107] The sensor assembly 28 can include two or more light emitting portions 36 that do not create overlapping detection cones within the nominal range of the sensors 28. A first cone of light defines a first sensing region and a second cone of light defines a second sensing region. If a user is detected in the first sensing region alone or the second sensing region alone, then the sensor assembly 28 signals the control-

ler 50, which activates a first level of light from the light sources 30. In certain variants, if a user is concurrently detected in the first and second sensing regions, then the sensor assembly 28 signals the controller 50 to activate a second level of light from the light sources 30. In some embodiments, the first level of light is brighter than the second level of light. In other embodiments, the second level of light is brighter than the first level of light.

[0108] Activation of the light sources 30 or adjusting the amount of light emitted from the light sources 30 can be based on factors other than the presence of a user within a sensing region. For example, the amount of light emitted from the light sources 30 can adjust based on motion within the detection zone and nominal range of the sensor 28. Certain implementations are configured such that, if a user lifts his/her hand in an upward motion, then the controller signals for the amount of light to increase, and if a user lowers his/her hand in a downward motion, then the controller signals for the amount of light to decrease.

[0109] Once a light source 30 activates, the light source 30 can remain activated so long as the sensor assembly 28 detects an object in a sensing region. Alternatively, the light source 30 remains activated for a pre-determined period of time. For example, activating the light source 30 can initialize a timer. If the sensor assembly 28 does not detect an object before the timer runs out, then the light source 30 is deactivated. If the sensor assembly 28 detects an object before the timer runs out, then the controller 50 reinitializes the timer, either immediately or after the time runs out.

[0110] The one or more sensing regions can be used in any type of configuration that allows the user to control an aspect of the operation of the mirror assembly 2. For example, the one or more sensing regions can be used to trigger the mirror assembly 2 to emit different levels of light, operate for varying durations of time, pivot the mirror, or any other appropriate parameter.

[0111] In several embodiments, the mirror assembly 2 has one or more modes of operation, for example, an on mode and an off mode. A controller 50 can activate different modes based on signals received from different sensing regions, motions, or any other parameter. Any of the modes described below can be used separately or in combination with each other.

[0112] The mirror assembly 2 can include a task mode. When the task mode is activated, the mirror assembly 2 can trigger a light source 30 to remain activated or cause the sensor to enter a hyper mode (e.g., during which the sensor is configured to have increased sensitivity to movement within a zone, or to have a larger or wider sensitivity zone, or to have some other increased sensitivity signal detection) for a pre-determined period of time. For example, in some embodiments, the task mode can be especially useful when the user plans to use the mirror assembly 2 for an extended period of time, especially if the user's body position is substantially still for an extended period, to avoid intermittent loss of lighting while the user is still looking into the mirror. The task mode can trigger a light source 30 to remain activated for a predetermined amount of time, even if the user is not detected within a sensing region. The pre-determined amount of time can be less than or equal to about: 3 minutes, 5 minutes, 10 minutes, or any other suitable period of time. If the sensor assembly 28 does not detect a user before the timer runs out, then the mirror assembly 2 deactivates task mode. In certain

embodiments, the mirror assembly 2 remains in task mode until the user signals a light source 30 to deactivate.

[0113] The mirror assembly 2 can include a power saver mode. When the power saver mode is activated, the light source 30 emits less light than the mirror assembly 2 when not in power saver mode. The power saver mode can be user-activated and can be used when a user plans to use the mirror for a relatively long period of time. Alternatively, the mirror assembly 2 enters power saver mode automatically as a transition between on mode and off mode. For example, a controller 50 can initialize a timer when a light source 30 activates. If the sensor assembly 28 does not detect a user before the timer runs out, then the controller 50 enters power saver mode and initializes a second timer. If the sensor assembly 28 does not detect a user before the second timer runs out, then the controller 50 deactivates the light source 30.

[0114] The mirror assembly 2 can include a hyper mode. As described above, in some embodiments, the mirror assembly 2 has two light emitting portions 36, each emitting a cone of light. In certain implementations, the controller 50 only triggers the light sources 30 to activate when the sensor assembly 28 detects an object in the region where the two cones of light intersect (e.g., the primary sensing region). In some embodiments, after the light source 30 has been activated, the mirror assembly 2 enters hyper mode. The controller 50 can keep the light sources 30 activated as long as the sensor assembly 2 detects the user in either one or both of the cones of light (the secondary or the primary sensing regions). The secondary sensing region can be different from the primary sensing region. For example, the secondary sensing region can be larger than the primary sensing region. In some embodiments, this allows the user to move around and still keep the light source 30 activated. Hyper mode can also help save power by preventing unintentional activation when the user is near a periphery of the mirror assembly 2.

[0115] The mirror assembly 2 can also include ambient light sensing capabilities. For example, when the ambient light is relatively low, the light emitting from the light source 30 will be brighter than if the ambient light is relatively bright. The light receiving portion 38 can detect both ambient light and light emitted from the transmitter 36, or the mirror assembly 2 can include a second sensor assembly for detecting ambient light.

[0116] The controller 50 can adjust the amount of signal necessary to trigger a light source 30 based on the amount of detected ambient light. For example, the amount of detected light required to activate the light sources 30 can be proportional to the ambient light. Such a configuration can allow the light source 30 to be activated even when the level of ambient light is modest (e.g., in dimmed bathroom lighting). When the ambient light is less than or equal to a first level, the controller 50 activates light source 30 when a first level of the reflected signal is detected. When the ambient light is greater than the first level, the controller 50 activates light source 30 when a second level (e.g., greater than the first level) of the reflected signal is detected.

[0117] The controller 50 can also adjust the amount of light emitted by the light sources 30 based on the ambient light. Such a configuration can, for example, avoid emitting a starting burst of very bright light that would be uncomfortable to a user's eyes, especially when the user's eyes were previously adjusted to a lower light level, such as when the surrounding



environment is dim. For example, the amount of light emitted by the light sources 30 can be proportional to the amount of ambient detected light.

[0118] The controller 50 can also gradually increase the level of emitted light from the light sources 30 when the light sources 30 are activated and/or gradually decrease the amount of light emitted from the light sources 30 when the light sources 30 are deactivated. Such a configuration can inhibit discomfort to a user's eyes when the light sources 30 turn on.

[0119] The mirror assembly 2 can also include a calibration mode. For example, the calibration mode can calibrate the different sensing regions with different output characteristics as desired by the user. An algorithm can be configured to utilize multiple sensing regions to perform different functions. For example, a user can configure a first sensing region to correspond with a first level of light (e.g., lower intensity light) and configure a second sensing region to correspond with a second level of light (e.g., higher intensity light). In another example, the user can adjust the size (e.g., width or height) of the sensing region. The user can designate a first sensing region to correspond with a first level of light and designate a second sensing region to correspond with a second level of light. This calibration mode can be triggered by a user indicator, such as pressing a button, activating a sensor, or any other appropriate mechanism.

[0120] In some embodiments, an ideal sensing region is designed so that the center of a user's face is generally positioned at about the center of the minor portion, at a suitable perpendicular distance away from the minor to permit the user to generally closely fit the user's face within the outer periphery of the minor. A proximity sensor, generally positioned at the top region of the minor, can be tilted downwardly at an angle below horizontal (e.g., at least about 10 degrees downward, such as about 15 degrees downward), and an algorithm can trigger a power change to the mirror when a user's face (or any other object) is detected within a predetermined range of distances in a perpendicular forward direction from the front face of the mirror. For example, in some embodiments, the first region can be within a range of at least about 10 inches and/or less than or equal to about 12 inches (e.g., about 11 inches) from the front face of the mirror, and the second region can be in a range of at least about 7 inches and/or less than or equal to about 9 inches (e.g., about 8 inches) from the front face of the mirror.

[0121] An algorithm can be configured to send a command to activate the light sources 30 based on the detected signal. The algorithm can also be configured to emit different levels of light or vary durations of time. The algorithm can also be configured to send a command to trigger one or more modes, including any of the modes discussed above. The command can vary based on the signal received. For example, the signal can depend on the distance between an object and the sensor assembly 28, and/or other parameters such as duration or path of motion.

[0122] The algorithm can initialize a timer when a light source is activated. The timer can run for at least 30 seconds and/or less than or equal to 60 seconds, or any other quantity of time. In some embodiments, the timer can run for less than 30 seconds. In some embodiments, the timer can run for about five seconds. In some embodiments, the light source will immediately turn off when the time runs out. In some embodiments, the light will remain activated so long as the sensor assembly 28 detects an object before time runs out. If the sensor assembly 28 detects the object, the timer can immedi-

ately restart, or restart when the time runs out. If the sensor assembly 28 does not detect an object before the time runs out, then the light source will turn off.

[0123] The algorithm can incorporate a delay that deactivates the sensor or otherwise prevents a light source 30 from emitting light immediately after the light source 30 deactivates. The delay can be for 1 second, 5 seconds, or any other amount of time. The delay helps prevent the user from unintentionally triggering the light source 30. During the delay period, the light source 30 will not emit light even if an object is in a sensing region during the delay period. If the sensor assembly 28 detects an object after the delay period, the light sources 30 can emit light again.

[0124] The level of light emitted from the light sources 30 does not depend solely or at all on the length of time that the user remains in the sensing region. The level of light emitted from the light sources 30 can differ depending on the location of the user in a different sensing region, even if certain other parameters are the same (such as the length of time that the user is sensed in a region).

[0125] The mirror assembly 2 can also include an algorithm configured to send a command to trigger the light sources 30 to activate based on the detected signal. For example, the algorithm 200 can resemble the flow chart depicted in FIG. 13. Beginning at start block 202, the controller initializes mirror assembly hardware and variables in operation block 204. Moving on to decision block 206, if the signal is detected in a first sensing region, then the controller activates first level of light in operation block 208. If a signal is not detected in a first sensing region, then the algorithm moves on to decision block 210.

[0126] If a signal is detected in a second region, then the controller activates a second level of light in operation block 212. If a signal is not detected in a second sensing region, then the algorithm moves on to decision block 214. If a signal is detected for a task mode then the controller activates a third level of light in operation block 216.

[0127] The third level of light can be a power saving level of light, such as if the user plans to keep the light source 30 activated for a relatively long period of time (e.g., 30 minutes or longer). After the third level of light is activated, a timer is initialized (block 218). The timer can be for 30 seconds or any other period of time. If a user is not detected within the sensing region during the 30 second timer, then the light source 30 turns off and the algorithm returns to just after the hardware and variables initialization in operation block 104. If a user is detected in a sensing region within the 30 second timer, then the 30 second timer repeats itself.

[0128] In some embodiments, the minor assembly 2 can include an algorithm configured to maintain the light source (e.g., LED) brightness at a generally constant level even as the battery capacity is nearing the end of its life (necessitating a recharge) by adjusting the electrical characteristics of the power source supplied to the light source depending on the stage of battery life (e.g., increasing the voltage as the current decreases or increasing the current as the voltage decreases).

[0129] Algorithm 200 may not include all of the blocks described above, or it may include more decision blocks to account for additional sensing regions, other modes, or other parameters as described throughout this disclosure.

[0130] In some embodiments, the mirror assembly 2 can include an algorithm configured to detect whether the mirror was inadvertently activated, such as with a false trigger or by the presence of an inanimate object. For example, when the

sensor detects an object, the controller can initialize a timer. If the minor assembly 2 does not detect any movement before the timer runs out, then the light sources will turn off. If the mirror assembly 2 does detect movement, then the timer can re-initialize.

**[0131]** As noted above, the minor assembly 2 can include a processor, which can control, by various scheme and algorithms, input and output characteristics and functions of the mirror assembly 2. The minor assembly 2 can also include memory, such as firmware, to store the various control schemes and algorithms, as well certain instructions and/or settings related to various characteristics of the minor assembly 2. For example, the memory can include instructions and/or settings regarding the size of the sensing regions, the sensitivity of the sensors, the level of output light, the length of various timers, and otherwise.

**[0132]** The minor assembly 2 can be configured such that a user can modify (e.g., update, program, or otherwise) the memory, such as by connecting the minor assembly 2 to a computer. For example, the mirror 2 can be communicatively connected with a computer via the port 24 (e.g., using a USB, cable). Data can be transferred between the computer and the minor assembly 2 via the port 24. The mirror assembly 2 can alternatively be configured to communicate with a computer wirelessly, such as by a cellular, Wi-Fi, or Bluetooth® network, infrared, or otherwise.

**[0133]** When the minor assembly 2 is in communication with the computer, a control panel may be displayed on the computer. The control panel may allow the user adjust various input and output characteristics for the mirror assembly 2. For example, a user can use the control panel to adjust the output of the emitting portions 36a and 36b and/or the sensitivity of the transmitter 36a, 36b. The user can also configure the light levels associated with the first and second sensing regions. In another example, the user can adjust the size (e.g., depth, width, and/or height) of one or more of the sensing regions. In some implementations, the user can use the control panel to modify the operation and output (e.g., intensity and/or color of the light) of the light source 30 based on certain conditions, such as the time of day, level of ambient light, amount of battery power remaining, and otherwise. In certain variants, the ability to modify the operational parameters of the minor assembly 2 with the control panel can reduce or obviate the need for one or more adjustment devices (e.g., buttons, knobs, switches, or the like) on the minor assembly 2, thereby providing a generally uniform exterior surface of the minor assembly 2 (which can facilitate cleaning) and reducing the chance of unintentional adjustment of the operational parameters (such as when transporting the mirror assembly 2).

**[0134]** When the mirror assembly 2 is in communication with the computer, data can be transferred from the mirror assembly 2 to the computer. For example, the mirror assembly 2 can transfer data, such as power consumption, estimated remaining battery power, the number of activations and/or deactivations of the light source 30, the length of use (e.g., of individual instances and/or in total) of the light source 30, and otherwise. Software can be used to analyze the transferred data, such as to calculate averages, review usage statistics (e.g., during specific periods), recognize and/or draw attention to unusual activity, and display usage statistics on a graph. Transferring usage statistics from the minor assembly 2 to the computer allows the user to monitor usage and enables the user to calibrate different characteristics of the minor assembly 2 (e.g., based on previous usage and param-

eters). Transferring data from the mirror assembly 2 to the computer can also reduce or avoid the need for one or more adjustment or display devices on the minor assembly itself.

**[0135]** When the mirror assembly 2 is in communication with the computer, the minor the computer can also transfer data to the minor assembly 2. Furthermore, when the minor assembly 2 is in communication with the computer, electrical potential can be provided to the battery 26 before, during, or after such two-way data transfer.

**[0136]** Although the vanity minor has been disclosed in the context of certain embodiments and examples, it will be understood by those skilled in the art that the present disclosure extends beyond the specifically disclosed embodiments to other alternative embodiments and/or uses of the subject matter and obvious modifications and equivalents thereof. In addition, while several variations of the vanity mirror have been described in detail, other modifications, which are within the scope of the present disclosure, will be readily apparent to those of skill in the art based upon this disclosure. It is also contemplated that various combinations or sub-combinations of the specific features and aspects of the embodiments can be made and still fall within the scope of the present disclosure. It should be understood that various features and aspects of the disclosed embodiments can be combined with or substituted for one another in order to form varying modes of the vanity minor. Thus, it is intended that the scope of the subject matter herein disclosed should not be limited by the particular disclosed embodiments described above.

The following is claimed:

1. A minor assembly comprising:

- a housing portion;
- a minor coupled with the housing portion;
- a light source disposed at a periphery of the minor;
- a light path having a length and being positioned around at least a portion of the periphery of the minor; and
- a light scattering region disposed along the length of the light path and having a pattern density, the light scattering region configured to encourage a portion of the light impacting the light scattering region to be emitted out of the light path and toward a user of the mirror, the pattern density being less dense in a region spaced from the light source and the pattern density being greater in a region generally opposite the light source along the periphery of the mirror, thereby facilitating a substantially constant amount of light emitted along the length of the light path.

2. The minor assembly of claim 1, wherein the scattering region is comprised of light scattering elements in the region generally adjacent the light source that are smaller than light scattering elements in the region generally opposite the light source.

3. The minor assembly of claim 1, wherein the light source is positioned near an upper portion of the mirror.

4. The mirror assembly of claim 1, wherein the light path is a light pipe disposed along substantially all of the periphery of the mirror.

5. The mirror assembly of claim 1, wherein the light source emits light in a direction generally orthogonal to a viewing surface of the minor.

6. The mirror assembly of claim 1, wherein the light path comprises a first end and a second end, and wherein the light source emits light into the first end and another light source emits light into the second end.

7. The mirror assembly of claim 2, wherein the light scattering elements are generally uniformly distributed along at least a portion of the light path.

8. A mirror assembly comprising:  
a housing portion;  
a minor coupled with the housing portion;  
one or more light sources disposed at a periphery of the minor, the one or more light sources configured to emit light in a direction generally orthogonal to a viewing surface of the minor;  
a light pipe having a length and being disposed along substantially all of the periphery of the mirror, the light pipe configured to receive light from the one or more light sources and distribute the light generally consistently along the length, thereby providing a substantially constant level of illumination to the periphery of the mirror.

9. The mirror assembly of claim 8, wherein the one or more light sources includes a first light source configured to project light in a first direction around the periphery of the minor and a second light source configured to project light in a second direction around the periphery of the minor.

10. The mirror assembly of claim 8, wherein the one or more light sources is two light sources.

11. The minor assembly of claim 8, wherein each of the light sources uses less than three watts of power.

12. The minor assembly of claim 8, wherein the one or more light sources have a color rendering index of at least 90.

13. The minor assembly of claim 8, wherein the one or more light sources includes a light emitting diode.

14. The mirror assembly of claim 8, wherein the light pipe is configured to transmit at least about 95% of the light emitted from the one or more light sources.

15. A method of manufacturing a mirror assembly, the method comprising:

coupling a mirror and a housing portion;  
disposing a light source at a periphery of the mirror;  
positioning a light path around at least a portion of the periphery of the mirror;  
disposing a light scattering region along a length of the light path, the light scattering region having a pattern density, the light scattering region configured to encourage a portion of the light impacting the light scattering region to be emitted out of the light path, the pattern density being less dense in a region generally adjacent the light source and the pattern density being greater in a region generally opposite the light source along the periphery of the minor, thereby facilitating a substantially constant amount of light emitted along the length of the light pipe.

16. The method of claim 15, further comprising positioning the light source near an upper portion of the minor.

17. The method of claim 15, further comprising disposing the light path around substantially all of the periphery of the mirror.

18. The method of claim 15, further comprising positioning the light source to emit light in a direction generally orthogonal to a viewing surface of the mirror.

19. The method of claim 15, further comprising positioning the light source to emit light into a first end of the light path and positioning another light source to emit light into a second end of the light path.

20. The method of claim 15, further comprising disposing light scattering elements in the scattering region in a generally uniform pattern along at least a portion of the light path.

\* \* \* \* \*